



Spur
Gears

Helical
Gears

Internal
Gears

Racks

CP Racks
& Pinions

Miter
Gears

Bevel
Gears

Screw
Gears

Worm
Gear Pair

Bevel
Gearboxes

Other
Products



■ Features

- ① **Compactness**
Simplicity of design, enclosed in an aluminum die-cast casing.
- ② **Low noise and high efficiency**
The spiral bevel gears are made of case-hardened alloy steel.
- ③ **Freedom of installing orientation**
The unit can be installed easily in any orientation.
- ④ **Maintenance-free**
High-grade grease is sealed in the casting before shipping.
- ⑤ **Selective speed ratio**
Gear ratios of 1/1/ or 1/2 are available to meet most applications.

■ Lubrication

A standard volume of lubricant is sealed at the factory before shipping.

Model	Volume of lubricant	Lubrication	
KBX-10 Type	10g	Grease	The grease contains the Li Extreme Pressure additive NLGI-00
KBX-15 Type	30g		
KBX-20 Type	50g		

■ Points to observe during use

1. Environmental space suitable for installation
 - ① Ambient temperature -10°C to 40°C
 - ② Ambient humidity 80% or less
 - ③ Atmosphere Well-ventilated, dust-free air not including corrosive gas and steam.
 - ④ Location Indoors

2. Mounting methods
 - ① Bolt the unit firmly on a machined plain surface free from vibrations.
 - ② No secondary operations such as adding bolt holes can be performed on the casing. Also, do not disassemble or modify the units. There is a danger that the gearbox will break.
 - ③ When used in applications where oil contamination is undesirable such as in a food processing machines, please use preventive measures against oil leaks due to malfunction or the units wearing out.
3. Connections with mating machinery
 - ① Before connecting to the mating machinery, please verify the direction of the shaft rotation to avoid breakage of the equipment.
 - ② Take care not to cause interference with an oil seal or case surface when fitting a coupling, sprocket, pulley, gear, etc. to gearbox shafts, especially for models without steps on the shaft. We recommend an H7 tolerance for the bore.
 - ③ In the case of direct connection, alignment must be made accurately so that the gearbox shaft and the mating shaft are inline. We recommend flexible couplings.
 - ④ When using a chain, belt or gear drive, position the gearbox shaft and the mating shaft accurately parallel with each other so that a line connecting the center of one shaft to the center of the other shaft makes a right angle with the shafts.
4. Operating precautions
 - ① Do not get near or touch rotating portions of the machine such as the shafts during operations. You may get caught and injure yourself.
 - ② Stop the operation immediately when the noise level or the temperature rises abnormally. Do not restart until all of the causes are analyzed and proper repairs are made.
 - ③ Sudden reversal of the direction of rotation could affect the gearbox and mating machinery. Be sure to stop the unit before reversing the rotation.
 - ④ Be sure to keep the load torque and overhang load (O.H.L.) within the allowable range during operation.

KBX Performance Chart

Speed Ratio	Type	Specifications	X-axis revolutions per minute (rpm)												Allowable thrust load (N) [kgf]	
			50	100	200	300	400	600	900	1200	1500	1800	2500	3600	X-axis	Y-axis
1 : 1	KBX-101	Allowable Power (kW)	0.01	0.02	0.05	0.07	0.09	0.14	0.20	0.26	0.31	0.35	0.38	0.44	59 {6}	69 {7}
		X&Y-axis torque (N · m) [kgf · m]	2.35 {0.24}	2.35 {0.24}	2.25 {0.23}	2.25 {0.23}	2.16 {0.22}	2.16 {0.22}	2.06 {0.21}	2.06 {0.21}	1.96 {0.20}	1.86 {0.19}	1.47 {0.15}	1.18 {0.12}		
		X-axis O.H.L. (N) [kgf]	78 {8}	78 {8}	78 {8}	78 {8}	69 {7}	69 {7}	69 {7}	69 {7}	69 {7}	59 {6}	49 {5}	39 {4}		
		Y-axis O.H.L. (N) [kgf]	127 {13}	127 {13}	118 {12}	118 {12}	118 {12}	118 {12}	108 {11}	108 {11}	108 {11}	98 {10}	78 {8}	59 {6}		
		Efficiency (Reference values)	90%													
	KBX-151	Allowable Power (kW)	0.05	0.09	0.18	0.27	0.35	0.51	0.75	0.96	1.16	1.30	1.44	1.66	98 {10}	118 {12}
		X&Y-axis torque (N · m) [kgf · m]	8.82 {0.90}	8.82 {0.90}	8.62 {0.88}	8.53 {0.87}	8.33 {0.85}	8.13 {0.83}	7.94 {0.81}	7.64 {0.78}	7.35 {0.75}	6.86 {0.70}	5.49 {0.56}	4.41 {0.45}		
		X-axis O.H.L. (N) [kgf]	255 {26}	255 {26}	255 {26}	245 {25}	245 {25}	235 {24}	225 {23}	216 {22}	216 {22}	186 {19}	157 {16}	127 {13}		
		Y-axis O.H.L. (N) [kgf]	294 {30}	294 {30}	284 {29}	284 {29}	274 {28}	265 {27}	265 {27}	255 {26}	245 {25}	216 {22}	176 {18}	147 {15}		
		Efficiency (Reference values)	90%													
	KBX-201	Allowable Power (kW)	0.09	0.18	0.36	0.52	0.68	0.95	1.38	1.78	2.15	2.50	2.55	2.95	196 {20}	274 {28}
		X&Y-axis torque (N · m) [kgf · m]	17.6 {1.80}	17.6 {1.80}	17.2 {1.75}	16.7 {1.70}	16.2 {1.65}	15.2 {1.55}	14.7 {1.50}	14.2 {1.45}	13.7 {1.40}	13.2 {1.35}	9.80 {1.00}	7.84 {0.80}		
X-axis O.H.L. (N) [kgf]		353 {36}	353 {36}	343 {35}	333 {34}	333 {34}	323 {33}	314 {32}	304 {31}	294 {30}	265 {27}	216 {22}	176 {18}			
Y-axis O.H.L. (N) [kgf]		529 {54}	529 {54}	519 {53}	510 {52}	500 {51}	490 {50}	470 {48}	451 {46}	441 {45}	392 {40}	314 {32}	255 {26}			
Efficiency (Reference values)		90%														
1 : 2	KBX-102	Allowable Power (kW)	0.005	0.01	0.02	0.03	0.04	0.06	0.09	0.12	0.14	0.16	0.17	0.20	59 {6}	69 {7}
		X&Y-axis torque (N · m) [kgf · m]	2.06 {0.21}	2.06 {0.21}	2.06 {0.21}	1.96 {0.20}	1.96 {0.20}	1.96 {0.20}	1.86 {0.19}	1.86 {0.19}	1.76 {0.18}	1.67 {0.17}	1.27 {0.13}	1.08 {0.11}		
		X-axis O.H.L. (N) [kgf]	88 {9}	88 {9}	88 {9}	88 {9}	88 {9}	78 {8}	78 {8}	78 {8}	78 {8}	69 {7}	59 {6}	49 {5}		
		Y-axis O.H.L. (N) [kgf]	137 {14}	137 {14}	137 {14}	127 {13}	127 {13}	127 {13}	127 {13}	118 {12}	118 {12}	108 {11}	88 {9}	69 {7}		
		Efficiency (Reference values)	90%										85%			
	KBX-152	Allowable Power (kW)	0.02	0.04	0.08	0.13	0.17	0.25	0.36	0.46	0.55	0.62	0.69	0.80	98 {10}	118 {12}
		X&Y-axis torque (N · m) [kgf · m]	8.43 {0.86}	8.43 {0.86}	8.23 {0.84}	8.13 {0.83}	8.04 {0.82}	7.84 {0.80}	7.55 {0.77}	7.25 {0.74}	7.06 {0.72}	6.57 {0.67}	5.29 {0.54}	4.21 {0.43}		
		X-axis O.H.L. (N) [kgf]	255 {26}	255 {26}	255 {26}	245 {25}	245 {25}	235 {24}	225 {23}	216 {22}	216 {22}	186 {19}	157 {16}	127 {13}		
		Y-axis O.H.L. (N) [kgf]	294 {30}	294 {30}	284 {29}	284 {29}	274 {28}	265 {27}	265 {27}	255 {26}	245 {25}	216 {22}	176 {18}	147 {15}		
		Efficiency (Reference values)	90%										85%			
	KBX-202	Allowable Power (kW)	0.05	0.10	0.19	0.28	0.37	0.53	0.77	0.99	1.15	1.31	1.40	1.57	196 {20}	274 {28}
		X&Y-axis torque (N · m) [kgf · m]	19.6 {2.00}	19.6 {2.00}	18.6 {1.90}	18.1 {1.85}	17.6 {1.80}	17.0 {1.73}	16.4 {1.67}	15.7 {16.0}	14.7 {1.50}	13.9 {1.42}	10.8 {1.10}	8.33 {0.85}		
X-axis O.H.L. (N) [kgf]		372 {38}	372 {38}	363 {37}	363 {37}	353 {36}	343 {35}	333 {34}	323 {33}	314 {32}	274 {28}	235 {24}	186 {19}			
Y-axis O.H.L. (N) [kgf]		588 {60}	588 {60}	578 {59}	568 {58}	559 {57}	539 {55}	529 {54}	510 {52}	490 {50}	441 {45}	363 {37}	294 {30}			
Efficiency (Reference values)		90%										85%				

- [CAUTION]**
- ① Be sure not to exceed the allowable values. Units with (1:2) reduction ratio have the slower speed in the Y-axis.
 - ② The values in the table are in effect when the service factor is 1. When the units are used under other conditions, refer to the Selection Guides.
 - ③ Overhang load (O.H.L.) means the load applied to the middle of the overhang shaft, perpendicular to the axis. When using the units under other conditions, refer to the factors K1 and K2 described in the Selection Guide.
 - ④ When the 1:2 speed ratio unit is used as a speed increaser (from the Y-axis to the X-axis), the X-axis torque becomes one half of the Y-axis torque shown in the table.
 - ⑤ The Y-axis torque of type T is the sum of the values on both right and left axis.
 - ⑥ The Y-axis O.H.L. of type T is the sum of the values on both right and left axis.





KBX Bevel Gearboxes

L Type



Spur Gears

Helical Gears

Internal Gears

Racks

CP Racks & Pinions

Miter Gears

Bevel Gears

Screw Gears

Worm Gear Pair

Bevel Gearboxes

Other Products

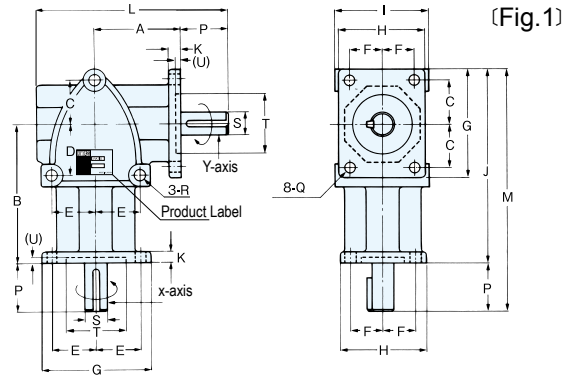

Catalog No.	Speed Ratio	A	B	C	D	E	F	G	H	I	J	K	L	M	P	Q	R	S
KBX-101L	1:1	37	58	18	18	18	14	46	38	40	82	5	82	102	20	φ 5.5	φ 6.5	φ 10
KBX-102L	1:2																	
KBX-151L	1:1	66	100	31	36	31	22	80	62	66	140	8	137	170	30	φ 8.5	φ 8.5	φ 15
KBX-152L	1:2																	
KBX-201L	1:1	80	120	36	36	36	26	92	72	76	166	10	168	206	40	φ 8.5	φ 8.5	φ 20
KBX-202L	1:2																	



KBX Bevel Gearboxes

T Type



Bevel Gears

Screw Gears

Worm Gear Pair

Bevel Gearboxes

Other Products

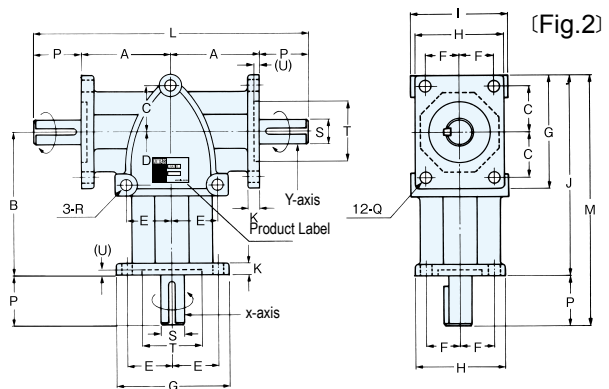

Catalog No.	Speed Ratio	A	B	C	D	E	F	G	H	I	J	K	L	M	P	Q	R	S
KBX-101T	1:1	37	58	18	18	18	14	46	38	40	82	5	114	102	20	φ 5.5	φ 6.5	φ 10
KBX-102T	1:2																	
KBX-151T	1:1	66	100	31	36	31	22	80	62	66	140	8	192	170	30	φ 8.5	φ 8.5	φ 15
KBX-152T	1:2																	
KBX-201T	1:1	80	120	36	36	36	26	92	72	76	166	10	240	206	40	φ 8.5	φ 8.5	φ 20
KBX-202T	1:2																	

Bevel Gearboxes

- [Caution]
- ① The arrow marks on the shafts are intended to show the relative direction of rotation. The units can be driven in the opposite direction as well.
 - ② In the unit, the X-axis rotates clockwise, and the Y-axis counter-clockwise.
 - ③ The key grooves in the X-axis and the Y-axis do not always coincide in phase with each other.
 - ④ The tolerance of shaft diameter is JIS h7
 - ⑤ The pinion gear is mounted on the x-axis (the input side) in 1 : 2 ratio units.
 - ⑥ The key dimensions are per JIS B 1301-1976 (Standard Grade)
 - ⑦ The backlash angles are measured at the X-axis (Input Shaft).

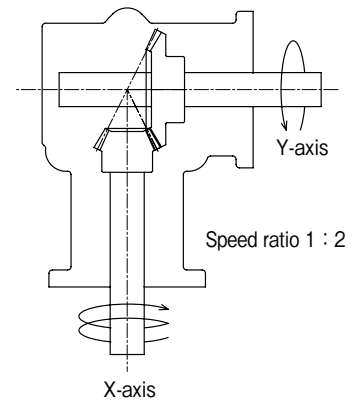
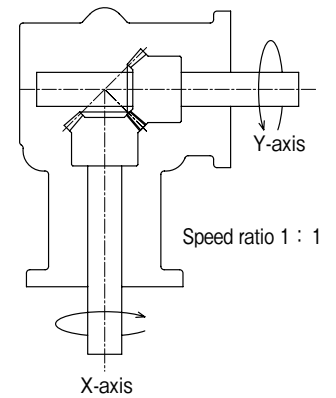

T	(U)	Key	Backlash of shaft rotation	Weight (kg)	Catalog No.
φ 26 _{H7}	(2)	1 x 15 ℓ (flat)	16' ~ 44'	0.40	KBX-101L
			30' ~ 1° 23'		KBX-102L
φ 42 _{H7}	(3)	5 x 5 x 27 ℓ	10' ~ 37'	1.80	KBX-151L
			19' ~ 1° 09'		KBX-152L
φ 52 _{H7}	(4)	6 x 6 x 35 ℓ	8' ~ 33'	3.10	KBX-201L
			15' ~ 60'		KBX-202L

KBX

Bevel Gearboxes

- [Caution]
- ① The arrow marks on the shafts are intended to show the relative direction of rotation. The units can be driven in the opposite direction as well.
 - ② In the unit, the X-axis rotates clockwise, and the Y-axis counter-clockwise.
 - ③ The key grooves in the X-axis and the Y-axis do not always coincide in phase with each other.
 - ④ The tolerance of shaft diameter is JIS h7.
 - ⑤ The pinion gear is mounted on the x-axis (the input side) in 1 : 2 ratio units.
 - ⑥ The key dimensions are per JIS B 1301-1976(Standard Grade)
 - ⑦ The backlash angles are measured at the X-axis (Input Shaft).

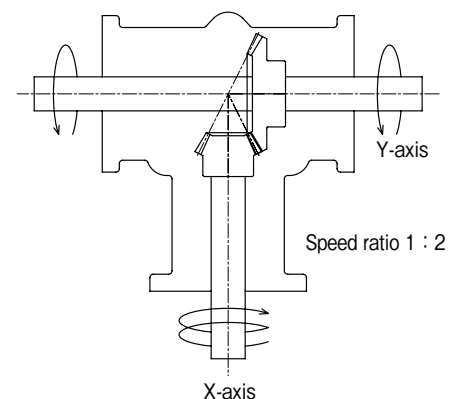
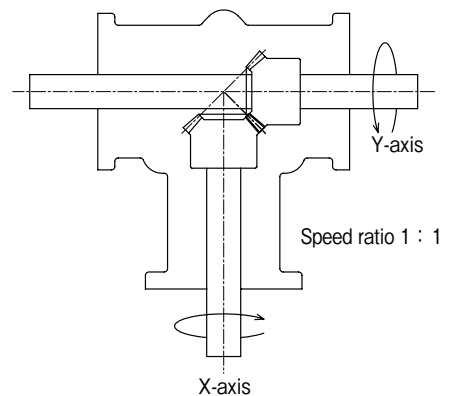

T	(U)	Key	Backlash of shaft rotation	Weight (kg)	Catalog No.
φ 26 _{H7}	(2)	1 x 15 ℓ (flat)	16' ~ 44'	0.50	KBX-101T
			30' ~ 1° 23'		KBX-102T
φ 42 _{H7}	(3)	5 x 5 x 27 ℓ	10' ~ 37'	2.20	KBX-151T
			19' ~ 1° 09'		KBX-152T
φ 52 _{H7}	(4)	6 x 6 x 35 ℓ	8' ~ 33'	3.40	KBX-201T
			15' ~ 60'		KBX-202T

Spur Gears

Helical Gears

Internal Gears

Racks

CP Racks & Pinions

Miter Gears

Bevel Gears

Screw Gears

Worm Gear Pair

Bevel Gearboxes

Other Products