



Description of duplex worm gears

The usual method of adjusting the backlash of a worm gear assembly is to modify the center distance. Once assembled, such adjustment requires a major rework of the gearbox housing. The use of duplex worm gears allows the backlash adjustment to be made by axially shifting the worm. This simplifies greatly the assembly and maintenance operations. Because of the unique characteristics of the product, please take time to study its construction and proper use.

Backlash adjustment mechanism and method of adjustment

The dual-lead worm is formed to give a difference between the right tooth surface and left tooth surface so that it provides a unique tooth profile in which the tooth thickness varies continuously, corresponding with the lead difference. (Fig.1)

The worm gear is also formed in its right and left tooth surface.

When such a worm and worm gear are set up at a constant assembly distance and the worm is moved in the axial direction, the tooth thickness of the worm in mesh with the worm gear changes making backlash adjustment possible.



An arrow marking on the outer circumference of the hub of the KHK duplex worm indicates the direction of assembly as well as acts as a guide for the backlash adjustment.

When the worm is held with arrow mark pointing right, the tooth thickness is thinner on the right and thicker on the left. Therefore, moving the worm to the right causes the thicker teeth to come into actual engagement with the worm gear, thereby reducing the backlash. (Fig.2)

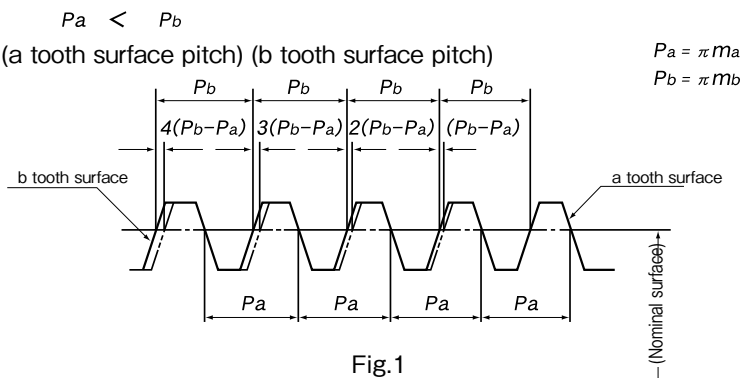

(CAUTION) The amount of change in backlash (Δj mm) in relation to the axial movement of the duplex worm shaft (V mm) can be calculated from the formula below.

$$\Delta j = 2V \frac{m_b - m_a}{m_a + m_b}$$

Where

m_a = Nominal Axial Module - (0.01 × Nominal Axial Module)

m_b = Nominal Axial Module + (0.01 × Nominal Axial Module)

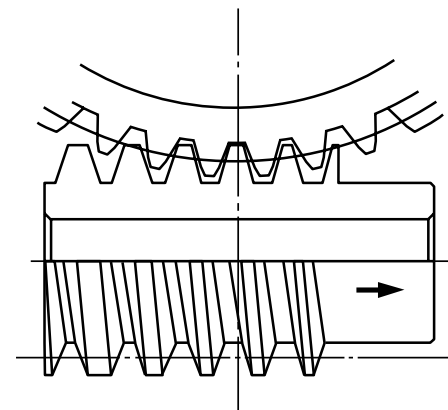

Reference tooth

Moving the worm in the direction of the arrow causes the backlash to decrease.

Fig. 2

(CAUTION) The KHK duplex worm is designed so that, for all modules, the backlash reduces by 0.02 mm when the worm is shifted 1 mm.

Application Examples

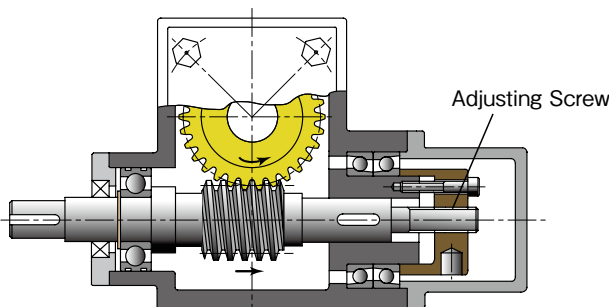

Adjustment by using Screws *

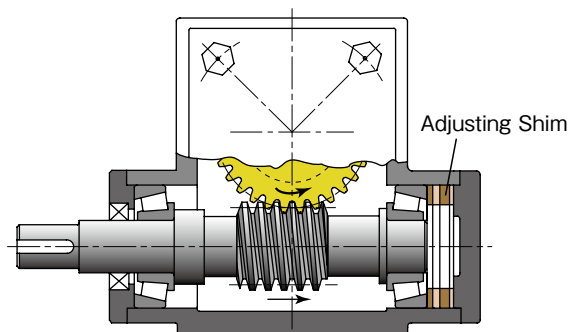

Adjustment by using Shims *

* The illustration above is a design example, not a design for machinery or a device in actual use.

Point of caution during assembly

KHK duplex worm gears differs in module between the right and left tooth surface and, therefore, you must orient the worm and worm wheel properly. Please carefully verify the following two aspects before proceeding with assembly.

1. Verifying the orientation of assembly

An arrow indicating the orientation of assembly is stamped on both the duplex worm and worm wheel. When assembling the worm and worm wheel, check the worm wheel of the arrow mark on the front such that the direction of arrow mark on the worm coincides with that on the worm wheel. Should the assembly be incorrect, the center distance "a" will become larger than the normal distance, resulting in difficulty of assembly and improper gear engagement. (Fig.3)

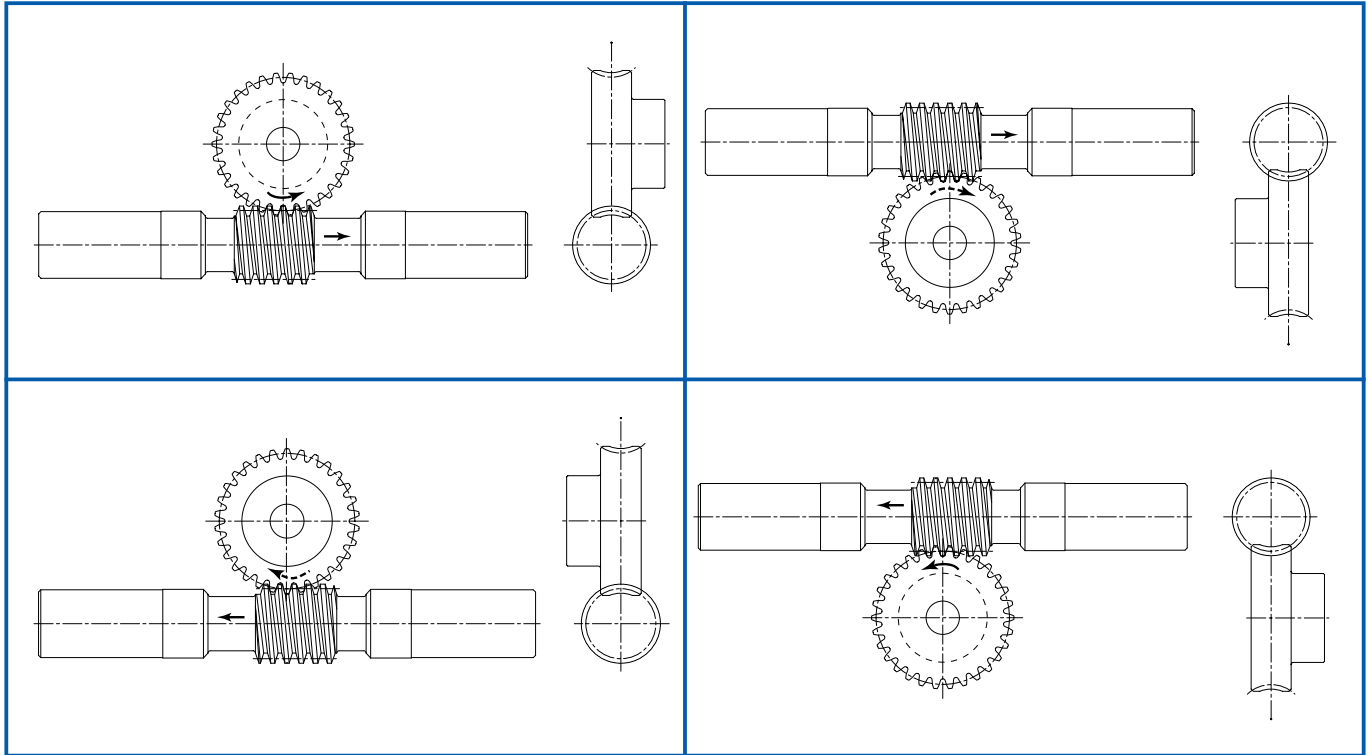

Arrow mark indicates the correct orientation of two gears when assembled. As shown, the two arrows must point in the same direction.

Fig. 3

2. Verifying the reference position

A V-groove (60°, 0.3 mm deep line) on tip peripheral of the duplex worm tooth marks the reference tooth. The gear set is designated to have a backlash of nearly zero (± 0.045) when the reference tooth is positioned in alignment with the center of rotation of the worm wheel with the center distance set at the value "a". (Fig.4)

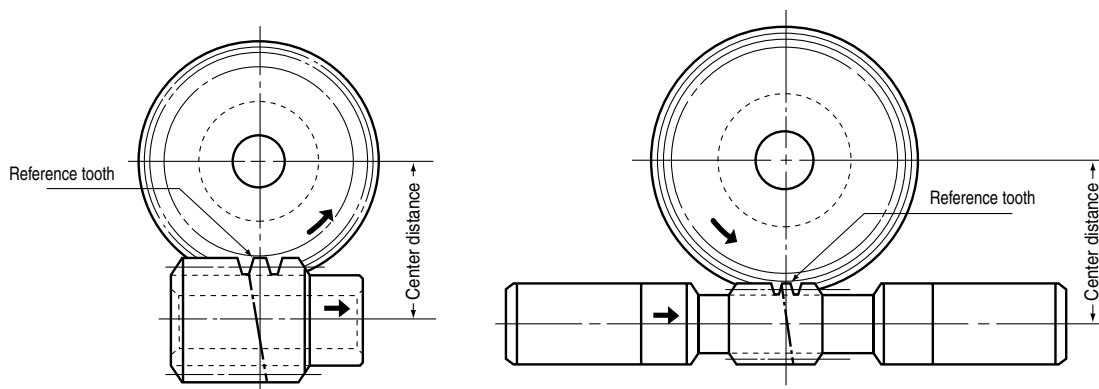

Fig. 4



Spur
Gears

Helical
Gears

Internal
Gears

Racks

CP Racks
& Pinions

Miter
Gears

Bevel
Gears

Screw
Gears

Worm
Gear Pair



Specifications	
Precision grade	KHK W 001 grade 1
Reference section of gear	Axial
Gear teeth	Standard full depth
Normal pressure angle	17° 30'
Material	SCM440
Heat treatment	Thermal refined, tooth surface induction hardened
Tooth hardness	45 ~ 55HRC

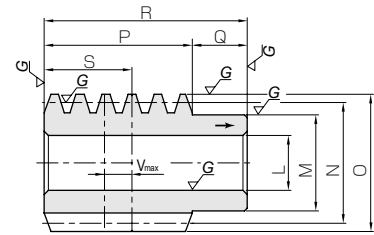

W4

Catalog No.	Nominal axial module	Number of start	Nominal lead angle	Hand of tread	Shape	Bore	Hub dia.	Pitch dia.	Outside dia.	Face width	Hub width	Total length
						L _{H7}	M	N	O	P	Q	R
KWGD2-R1	m2	1	3°41'	R	W4	14	25	31	35	36	14	50

Catalog No.	Nominal axial module	Number of start	Nominal lead angle	Hand of tread	Shape	Total length	Shaft length (L)	Neck length (L)	Face width	Neck length (R)	Shaft length (R)	Pitch dia.
						J	K	L	M	N	O	P
KWGDLS1.5-R1	m1.5	1	3°26'	R	W6	190	66	12	28	18	66	25
KWGDLS2-R1	m2	1	3°41'	R	W6	220	75	13	36	21	75	31

- [Caution on Product Characteristics]
- When the center distance is moved to reduce the backlash, the V max is the maximum amount of distance that you may shift without causing problems with the gear mesh. The V max is not a recommended value to use for adjustment when assembling.
 - For W6 Shaped Gears, the tolerances of the shaft diameter are set to S +0.2 and +0.1 (+0.40 and +0.35 for the ground area).
 - These worms produce axial thrust forces. See page 512 for more details.



Miter
Gears

Bevel
Gears

Screw
Gears

Worm
Gear Pair



Specifications	
Precision grade	KHK W 002 grade 1
Reference section of gear	Rotating plane
Gear teeth	Standard full depth
Normal pressure angle	17° 30'
Material	CAC702 (formerly JIS A&BC2)
Heat treatment	—
Tooth hardness	—

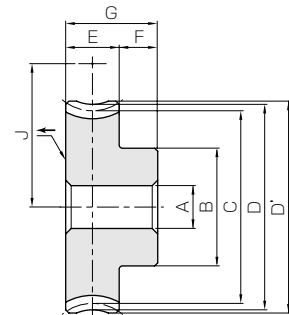

H1

Catalog No.	Reduction ratio	Nominal axial module	No. of teeth	Helix angle	Hand of tread	Shape	Bore	Hub dia.	Pitch dia.	Throat dia.	Outside dia.	Face width	Hub width
							A _{H7}	B	C	D	D'	E	F
AGDL1.5-20R1	20	m1.5	20	3°26'	R	H1	8	22	30	33	34.5	14	10
AGDL1.5-30R1	30		30	3°26'	R	H1	10	30	45	48	49.5	14	10
AGDL1.5-36R1	36		36	3°26'	R	H1	10	35	54	57	58.5	14	10
AGDL1.5-40R1	40		40	3°26'	R	H1	12	35	60	63	64.5	14	10
AGDL1.5-50R1	50		50	3°26'	R	H1	12	45	75	78	79.5	14	10
AGDL1.5-60R1	60		60	3°26'	R	H1	12	50	90	93	94.5	14	10
AGDL2-20R1	20	m2	20	3°41'	R	H1	12	33	40	44	46	18	15
AGDL2-30R1	30		30	3°41'	R	H1	15	40	60	64	66	18	15
AGDL2-36R1	36		36	3°41'	R	H1	15	45	72	76	78	18	15
AGDL2-40R1	40		40	3°41'	R	H1	15	45	80	84	86	18	15
AGDL2-50R1	50		50	3°41'	R	H1	15	50	100	104	106	18	15
AGDL2-60R1	60		60	3°41'	R	H1	15	60	120	124	126	18	15

- [Caution on Product Characteristics]
- The allowable torques shown in the table are the calculated values according to the assumed usage conditions. Please see page 510 for more details.
 - Duplex worms and worm wheels must be mated in a predetermined orientation, which is indicated by the arrows. Therefore, the arrow on the wheel does not indicate the mounting direction, but the rotating direction. Please refer to the Application Hints on page 515.

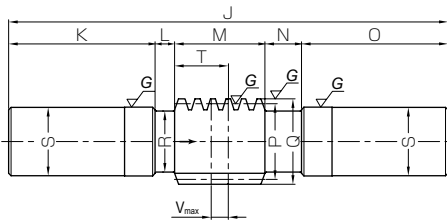

W6

Position of reference tooth	Max. allowable shift	Weight (kg)	Catalog No.
S	Vmax		
22	8	0.21	KWGDL2-R1

Outside dia.	Neck dia.	Shaft dia.	Position of reference tooth	Max. allowable shift	Weight (kg)	Catalog No.
Q	R	S	T	Vmax		
28	21	26	17	6	0.74	KWGDL1.5-R1
35	24	30	22	8	1.17	KWGDL2-R1

- [Caution on Secondary Operations]
- ① Please read "Caution on Performing Secondary Operations" (Page 512) when performing modifications and/or secondary operations for safety concerns. Haguruma Kobo, the KHK's system for quick modification of KHK stock gears is also available.
 - ② Due to the gear teeth being induction hardened, no secondary operations can be performed on tooth areas including the bottom land (approx. 1 to 2 mm).

AGDL

Duplex Worm Wheels



NOTE 1. Allowable torques for worm rotation (rpm)

Total length	Web thickness	Web O.D.	Mounting distance	Allowable torque (N·m) NOTE 1							Backlash (mm)	Weight (kg)	Catalog No.
				30 rpm	100 rpm	300 rpm	600 rpm	900 rpm	1200 rpm	1800 rpm			
G	(H)	(I)	J										
24	—	—	27.5	9.84	8.18	6.40	5.30	4.68	4.25	3.68	0±0.045	0.10	AGDL1.5-20R1
24	—	—	35	20.8	17.5	13.9	11.7	10.4	9.40	8.28	0±0.045	0.22	AGDL1.5-30R1
24	—	—	39.5	29.3	24.6	19.8	16.8	14.9	13.5	11.9	0±0.045	0.32	AGDL1.5-36R1
24	—	—	42.5	35.6	30.0	24.2	20.6	18.3	16.6	14.6	0±0.045	0.37	AGDL1.5-40R1
24	—	—	50	53.8	45.4	36.9	31.6	28.3	25.8	22.6	0±0.045	0.59	AGDL1.5-50R1
24	—	—	57.5	75.3	63.8	51.9	44.7	40.4	36.7	32.4	0±0.045	0.83	AGDL1.5-60R1
33	—	—	35.5	21.0	17.5	13.6	11.2	9.84	8.94	7.75	0±0.045	0.26	AGDL2-20R1
33	—	—	45.5	44.3	37.3	29.6	24.8	21.9	19.8	17.4	0±0.045	0.51	AGDL2-30R1
33	—	—	51.5	62.3	52.6	42.0	35.5	31.3	28.4	25.0	0±0.045	0.73	AGDL2-36R1
33	—	—	55.5	75.8	64.0	51.4	43.6	38.5	34.9	30.7	0±0.045	0.86	AGDL2-40R1
33	—	—	65.5	115	96.8	78.4	66.9	59.5	54.2	47.6	0±0.045	1.30	AGDL2-50R1
33	—	—	75.5	160	136	110	94.6	84.9	77.2	68.1	0±0.045	1.88	AGDL2-60R1

- [Caution on Secondary Operations]
- ① Please read "Caution on Performing Secondary Operations" (Page 512) when performing modifications and/or secondary operations for safety concerns. Haguruma Kobo, the KHK's system for quick modification of KHK stock gears is also available.



Spur
Gears

Helical
Gears

Internal
Gears

Racks

CP Racks
& Pinions

Miter
Gears

Bevel
Gears

Screw
Gears

Worm
Gear Pair



Specifications	
Precision grade	KHK W 001 grade 1
Reference section of gear	Axial
Gear teeth	Standard full depth
Normal pressure angle	17° 30'
Material	SCM440
Heat treatment	Thermal refined, tooth surface induction hardened
Tooth hardness	45 ~ 55HRC

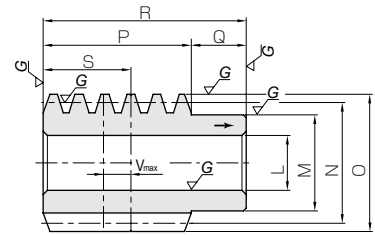

W4

Catalog No.	Nominal axial module	Number of start	Nominal lead angle	Hand of tread	Shape	Bore	Hub dia.	Pitch dia.	Outside dia.	Face width	Hub width	Total length
						L _{H7}	M	N	O	P	Q	R
KWGD2.5-R1	m2.5	1	3°52'	R	W4	18	30	37	42	48	17	65
KWGD3-R1	m3	1	3°54'	R	W4	20	35	44	50	54	20	74

Catalog No.	Nominal axial module	Number of start	Nominal lead angle	Hand of tread	Shape	Total length	Shaft length (L)	Neck length (L)	Face width	Neck length (R)	Shaft length (R)	Pitch dia.
						J	K	L	M	N	O	P
KWGDLS2.5-R1	m2.5	1	3°52'	R	W6	260	85	16	48	26	85	37
KWGDLS3-R1	m3	1	3°54'	R	W6	300	100	18	54	28	100	44

- [Caution on Product Characteristics]
- When the center distance is moved to reduce the backlash, the V max is the maximum amount of distance that you may shift without causing problems with the gear mesh. The V max is not a recommended value to use for adjustment when assembling.
 - For W6 Shaped Gears, the tolerances of the shaft diameter are set to S +0.2 and +0.1 (+0.40 and +0.35 for the ground area).
 - These worms produce axial thrust forces. See page 512 for more details.



Miter
Gears

Bevel
Gears

Screw
Gears

Worm
Gear Pair



Specifications	
Precision grade	KHK W 002 grade 1
Reference section of gear	Rotating plane
Gear teeth	Standard full depth
Normal pressure angle	17° 30'
Material	CAC702 (formerly JIS A&BC2)
Heat treatment	—
Tooth hardness	—

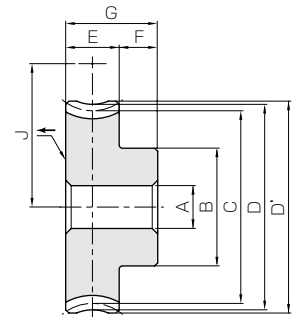

H1

Catalog No.	Reduction ratio	Nominal axial module	No. of teeth	Helix angle	Hand of tread	Shape	Bore	Hub dia.	Pitch dia.	Throat dia.	Outside dia.	Face width	Hub width
							A _{H7}	B	C	D	D'	E	F
AGDL2.5-20R1	20	m2.5	20	3°52'	R	H1	15	40	50	55	57.5	22	15
AGDL2.5-30R1	30		30	3°52'	R	H1	15	40	75	80	82.5	22	15
AGDL2.5-36R1	36		36	3°52'	R	H1	15	45	90	95	97.5	22	15
AGDL2.5-40R1	40		40	3°52'	R	HB	15	45	100	105	107.5	22	15
AGDL2.5-50R1	50		50	3°52'	R	HB	15	60	125	130	132.5	22	15
AGDL2.5-60R1	60		60	3°52'	R	HB	15	80	150	155	157.5	22	15
AGDL3-20R1	20	m3	20	3°54'	R	H1	20	50	60	66	69	28	17
AGDL3-30R1	30		30	3°54'	R	H1	20	55	90	96	99	28	17
AGDL3-36R1	36		36	3°54'	R	H1	20	60	108	114	117	28	17
AGDL3-40R1	40		40	3°54'	R	HB	20	60	120	126	129	28	17
AGDL3-50R1	50		50	3°54'	R	HB	20	70	150	156	159	28	17
AGDL3-60R1	60		60	3°54'	R	HB	20	80	180	186	189	28	17

- [Caution on Product Characteristics]
- The allowable torques shown in the table are the calculated values according to the assumed usage conditions. Please see page 510 for more details.
 - Duplex worms and worm wheels must be mated in a predetermined orientation, which is indicated by the arrows. Therefore, the arrow on the wheel does not indicate the mounting direction, but the rotating direction. Please refer to the Application Hints on page 515.



Duplex Worms

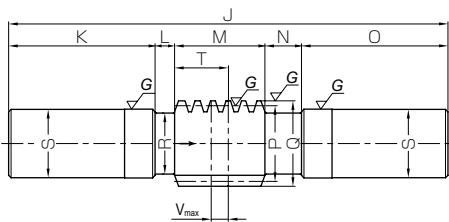

W6

Position of reference tooth	Max. allowable shift	Weight (kg)	Catalog No.
S	Vmax		
29	10	0.37	KWGDL2.5-R1
32	10	0.61	KWGDL3-R1

Outside dia.	Neck dia.	Shaft dia.	Position of reference tooth	Max. allowable shift	Weight (kg)	Catalog No.
Q	R	S	T	Vmax		
42	30	36	29	10	2.00	KWGDLs2.5-R1
50	34	40	32	10	2.95	KWGDLs3-R1

- [Caution on Secondary Operations]
- ① Please read "Caution on Performing Secondary Operations" (Page 512) when performing modifications and/or secondary operations for safety concerns. Haguruma Kobo, the KHK's system for quick modification of KHK stock gears is also available.
 - ② Due to the gear teeth being induction hardened, no secondary operations can be performed on tooth areas including the bottom land (approx. 1 to 2 mm).

AGDL

Duplex Worm Wheels

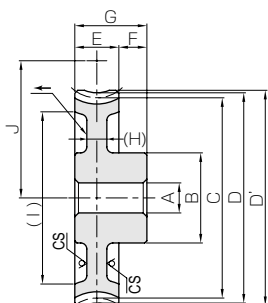

HB

* CS has a sand mold casting finish.

NOTE 1. Allowable torques for worm rotation (rpm)



Total length	Web thickness	Web O.D.	Mounting distance	Allowable torque (N·m) NOTE 1							Backlash (mm)	Weight (kg)	Catalog No.
				30 rpm	100 rpm	300 rpm	600 rpm	900 rpm	1200 rpm	1800 rpm			
37	—	—	43.5	38.1	31.4	24.5	20.1	17.6	16.0	13.8	0±0.045	0.45	AGDL2.5-20R1
37	—	—	56	80.5	67.1	53.1	44.5	39.1	35.5	30.9	0±0.045	0.88	AGDL2.5-30R1
37	—	—	63.5	113	94.5	75.5	63.8	56.0	51.0	44.3	0±0.045	1.25	AGDL2.5-36R1
37	(10)	(86)	68.5	138	115	92.4	78.3	68.8	62.7	54.4	0±0.045	1.14	AGDL2.5-40R1
37	(12)	(108)	81	208	174	141	120	106	97.3	84.3	0±0.045	1.93	AGDL2.5-50R1
37	(12)	(133)	93.5	291	245	198	170	152	139	121	0±0.045	2.90	AGDL2.5-60R1
45	—	—	52	65.0	53.3	41.5	33.8	29.5	26.9	22.8	0±0.045	0.81	AGDL3-20R1
45	—	—	67	137	114	90.0	74.7	65.5	59.5	51.2	0±0.045	1.65	AGDL3-30R1
45	—	—	76	193	160	128	107	93.8	85.6	73.4	0±0.045	2.32	AGDL3-36R1
45	(14)	(106)	82	235	195	157	131	115	105	90.1	0±0.045	2.19	AGDL3-40R1
45	(14)	(134)	97	355	295	239	202	178	163	140	0±0.045	3.26	AGDL3-50R1
45	(14)	(164)	112	497	415	336	285	254	233	200	0±0.045	4.48	AGDL3-60R1

- [Caution on Secondary Operations]
- ① Please read "Caution on Performing Secondary Operations" (Page 512) when performing modifications and/or secondary operations for safety concerns. Haguruma Kobo, the KHK's system for quick modification of KHK stock gears is also available.





Spur
Gears

Helical
Gears

Internal
Gears

Racks

CP Racks
& Pinions

Miter
Gears

Bevel
Gears

Screw
Gears

Worm
Gear Pair



Specifications	
Precision grade	KHK W 001 grade 1
Reference section of gear	Axial
Gear teeth	Standard full depth
Normal pressure angle	17° 30'
Material	SCM440
Heat treatment	Thermal refined, tooth surface induction hardened
Tooth hardness	45 ~ 55HRC

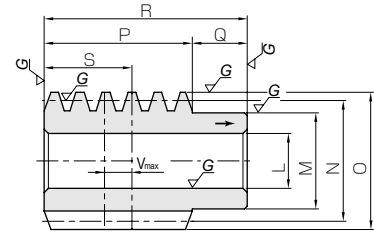

W4

Catalog No.	Nominal axial module	Number of start	Nominal lead angle	Hand of tread	Shape	Bore	Hub dia.	Pitch dia.	Outside dia.	Face width	Hub width	Total length
						L _{H7}	M	N	O	P	Q	R
KWGD3.5-R1	m3.5	1	3°47'	R	W4	24	44	53	60	62	23	85
KWGD4-R1	m4	1	3°41'	R	W4	28	50	62	70	74	26	100

Catalog No.	Nominal axial module	Number of start	Nominal lead angle	Hand of tread	Shape	Total length	Shaft length (L)	Neck length (L)	Face width	Neck length (R)	Shaft length (R)	Pitch dia.
						J	K	L	M	N	O	P
KWGDLS3.5-R1	m3.5	1	3°47'	R	W6	330	110	18	62	30	110	53
KWGDLS4-R1	m4	1	3°41'	R	W6	360	120	16	74	30	120	62

- [Caution on Product Characteristics]
- When the center distance is moved to reduce the backlash, the V max is the maximum amount of distance that you may shift without causing problems with the gear mesh. The V max is not a recommended value to use for adjustment when assembling.
 - For W6 Shaped Gears, the tolerances of the shaft diameter are set to S +0.2 and +0.1 (+0.40 and +0.35 for the ground area).
 - These worms produce axial thrust forces. See page 512 for more details.



Miter
Gears

Bevel
Gears

Screw
Gears

Worm
Gear Pair



Specifications	
Precision grade	KHK W 002 grade 1
Reference section of gear	Rotating plane
Gear teeth	Standard full depth
Normal pressure angle	17° 30'
Material	CAC702 (formerly JIS A&BC2) *
Heat treatment	—
Tooth hardness	—

* H5 shape have a hub made from S45C cast iron.

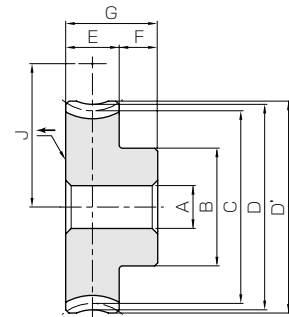

H1

Catalog No.	Reduction ratio	Nominal axial module	No. of teeth	Helix angle	Hand of tread	Shape	Bore	Hub dia.	Pitch dia.	Throat dia.	Outside dia.	Face width	Hub width
							A _{H7}	B	C	D	D'	E	F
AGDL3.5-20R1	20	m3.5	20	3°47'	R	H1	20	55	70	77	80.5	32	18
AGDL3.5-30R1	30		30	3°47'	R	H1	20	60	105	112	115.5	32	18
AGDL3.5-36R1	36		36	3°47'	R	H1	20	70	126	133	136.5	32	18
AGDL3.5-40R1	40		40	3°47'	R	HB	20	70	140	147	150.5	32	18
AGDL3.5-50R1	50		50	3°47'	R	HB	20	80	175	182	185.5	32	18
AGDL3.5-60R1	60		60	3°47'	R	HB	20	90	210	217	220.5	32	18
AGDL4-20R1	20	m4	20	3°41'	R	H1	20	60	80	88	92	35	20
AGDL4-30R1	30		30	3°41'	R	HB	20	65	120	128	132	35	20
AGDL4-36R1	36		36	3°41'	R	HB	20	75	144	152	156	35	20
AGDL4-40R1	40		40	3°41'	R	HB	20	75	160	168	172	35	20
AGDL4-50R1	50		50	3°41'	R	HB	20	90	200	208	212	35	20
AGDL4-60R1	60		60	3°41'	R	H5	30	120	240	248	252	35	20

- [Caution on Product Characteristics]
- The allowable torques shown in the table are the calculated values according to the assumed usage conditions. Please see page 510 for more details.
 - Duplex worms and worm wheels must be mated in a predetermined orientation, which is indicated by the arrows. Therefore, the arrow on the wheel does not indicate the mounting direction, but the rotating direction. Please refer to the Application Hints on page 515.

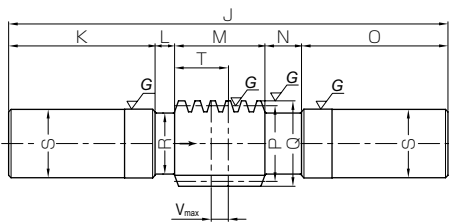

W6

Position of reference tooth	Max. allowable shift	Weight (kg)	Catalog No.
S	Vmax		
37	12	1.05	KWGDL3.5-R1
44	14	1.67	KWGDL4-R1

Outside dia.	Neck dia.	Shaft dia.	Position of reference tooth	Max. allowable shift	Weight (kg)	Catalog No.
Q	R	S	T	Vmax		
60	42	48	37	12	4.72	KWGDLs3.5-R1
70	50	56	44	14	7.10	KWGDLs4-R1

- [Caution on Secondary Operations] ① Please read "Caution on Performing Secondary Operations" (Page 512) when performing modifications and/or secondary operations for safety concerns. Haguruma Kobo, the KHK's system for quick modification of KHK stock gears is also available.
- ② Due to the gear teeth being induction hardened, no secondary operations can be performed on tooth areas including the bottom land (approx. 1 to 2 mm).

AGDL

Duplex Worm Wheels

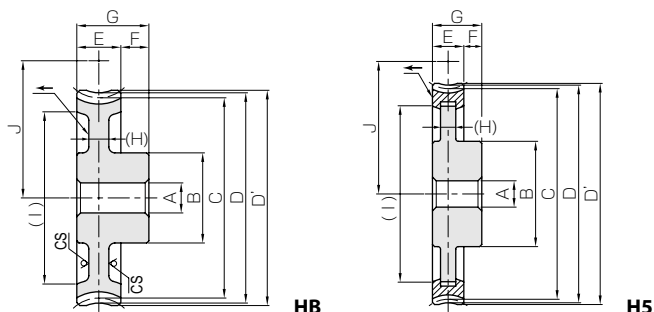

* CS has a sand mold casting finish.

NOTE 1. Allowable torques for worm rotation (rpm)



Total length	Web thickness	Web O.D.	Mounting distance	Allowable torque (N·m) NOTE 1							Backlash (mm)	Weight (kg)	Catalog No.
				30 rpm	100 rpm	300 rpm	600 rpm	900 rpm	1200 rpm	1800 rpm			
50	—	—	61.5	98.5	80.4	62.5	50.4	44.2	40.0	33.7	0±0.045	1.24	AGDL3.5-20R1
50	—	—	79	208	172	136	111	98.1	88.3	75.7	0±0.045	2.51	AGDL3.5-30R1
50	—	—	89.5	293	242	193	160	141	127	109	0±0.045	3.61	AGDL3.5-36R1
50	(15)	(124)	96.5	356	295	236	196	173	156	133	0±0.045	3.34	AGDL3.5-40R1
50	(16)	(155)	114	538	446	360	301	267	243	207	0±0.045	5.02	AGDL3.5-50R1
50	(16)	(189)	131.5	753	627	506	425	381	345	296	0±0.045	6.87	AGDL3.5-60R1
55	—	—	71	134	109	84.8	67.9	59.7	53.4	44.8	0±0.045	1.76	AGDL4-20R1
55	(17)	(99)	91	284	234	184	150	132	118	101	0±0.045	3.01	AGDL4-30R1
55	(17)	(121)	103	400	329	262	215	190	170	144	0±0.045	4.18	AGDL4-36R1
55	(17)	(137)	111	486	400	320	264	233	208	177	0±0.045	4.78	AGDL4-40R1
55	(17)	(177)	131	735	605	488	405	361	324	275	0±0.045	7.07	AGDL4-50R1
55	(17)	(200)	151	1030	851	687	572	515	461	393	0±0.045	11.5	AGDL4-60R1

- [Caution on Secondary Operations] ① Please read "Caution on Performing Secondary Operations" (Page 512) when performing modifications and/or secondary operations for safety concerns. Haguruma Kobo, the KHK's system for quick modification of KHK stock gears is also available.

Spur Gears
Helical Gears
Internal Gears
Racks
CP Racks & Pinions
Miter Gears
Bevel Gears
Screw Gears
Worm Gear Pair
Bevel Gearboxes
Other Products