

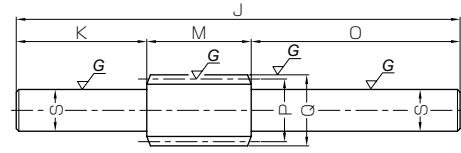

Specifications	
Precision grade	KHK W 001 grade 2
Reference section of gear	Axial
Gear teeth	Standard full depth
Normal pressure angle	20°
Material	SCM440
Heat treatment	Thermal refined, tooth surface induction hardened
Tooth hardness	45 ~ 55HRC



W5

Catalog No.	Axial module	Number of start	Lead angle	Hand of tread	Shape	Total length	Shaft length (L)	Neck length (L)	Face width	Neck length (R)	Shaft length (R)	Pitch dia.
						J	K	L	M	N	O	P
KWG0.5-R1	m0.5	1	3°11'	R	W5	65	19	—	12	—	34	9
KWG0.5-R2		2	6°20'	R	W5	65	19	—	12	—	34	9
KWG0.8-R1	m0.8	1	3°49'	R	W5	85	25	—	20	—	40	12
KWG0.8-R2		2	7°36'	R	W5	85	25	—	20	—	40	12

[Caution on Product Characteristics] ① These worms produce axial thrust forces. See page 512 for more details.

Spur Gears

Helical Gears

Internal Gears

Racks

CP Racks & Pinions

Miter Gears



Specifications	
Precision grade	KHK W 002 grade 2
Reference section of gear	Rotating plane
Gear teeth	Standard full depth
Normal pressure angle	20°
Material	CAC702 (formerly JIS A&BC2)
Heat treatment	—
Tooth hardness	—

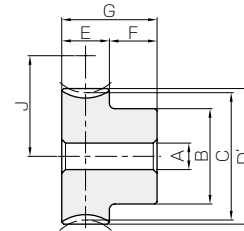

HA

Catalog No.	Reduction ratio	Transverse module	No. of teeth	Number of start	Helix angle	Hand of tread	Shape	Bore	Hub dia.	Pitch dia.	Throat dia.	Outside dia.	Face width
								A <sub>H7</sub>	B	C	D	D'	E
AG0.5-20R1	20	m0.5	20	1	3°11'	R	HA	4	9	10	—	11	5
AG0.5-20R2	10		20	2	6°20'	R	HA	4	9	10	—	11	5
AG0.5-30R1	30		30	1	3°11'	R	HA	4	12	15	—	16	5
AG0.5-30R2	15		30	2	6°20'	R	HA	4	12	15	—	16	5
AG0.5-40R1	40		40	1	3°11'	R	HA	5	15	20	—	21	5
AG0.5-50R1	50		50	1	3°11'	R	HA	5	20	25	—	26	5
AG0.5-60R1	60	60	1	3°11'	R	HA	5	25	30	—	31	5	
AG0.8-20R1	20	m0.8	20	1	3°49'	R	HA	5	12	16	—	17.6	8
AG0.8-20R2	10		20	2	7°36'	R	HA	5	12	16	—	17.6	8
AG0.8-30R1	30		30	1	3°49'	R	HA	5	18	24	—	25.6	8
AG0.8-30R2	15		30	2	7°36'	R	HA	5	18	24	—	25.6	8
AG0.8-40R1	40		40	1	3°49'	R	HA	6	20	32	—	33.6	8
AG0.8-50R1	50		50	1	3°49'	R	HA	8	25	40	—	41.6	8
AG0.8-60R1	60	60	1	3°49'	R	HA	8	25	48	—	49.6	8	

[Caution on Product Characteristics] ① The allowable torques shown in the table are the calculated values according to the assumed usage conditions. Please see page 510 for more details.

Bevel Gearboxes

Other Products

Worm Gear Pair

Outside dia.	Neck dia.	Shaft dia.	Weight (kg)	Catalog No.
Q	R	S <sub>H7</sub>		
10	—	6	0.018	<b>KWG0.5-R1</b>
10	—	6	0.018	<b>KWG0.5-R2</b>
13.6	—	8	0.043	<b>KWG0.8-R1</b>
13.6	—	8	0.043	<b>KWG0.8-R2</b>

- [Caution on Secondary Operations] ① Please read "Caution on Performing Secondary Operations" (Page 512) when performing modifications and/or secondary operations for safety concerns. Haguruma Kobo, the KHK's system for quick modification of KHK stock gears is also available.
- ② Due to the gear teeth being induction hardened, no secondary operations can be performed on tooth areas including the bottom land (approx. 1 to 2 mm). Use carbide tools for the modification of the shaft area near the bottom land.

AGDL

## Worm Wheels

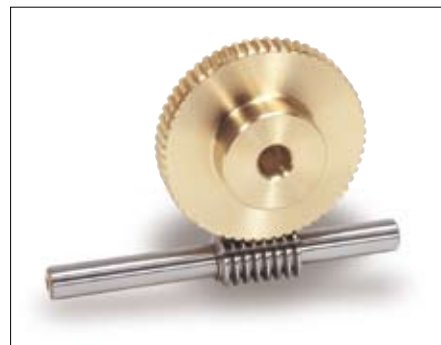

NOTE 1. Allowable torques for worm rotation (rpm)

Hub width	Total length	Web thickness	Web O.D.	Mounting distance	Allowable torque (N·m) NOTE 1							Backlash (mm)	Weight (kg)	Catalog No.
					30 <sub>rpm</sub>	100 <sub>rpm</sub>	300 <sub>rpm</sub>	600 <sub>rpm</sub>	900 <sub>rpm</sub>	1200 <sub>rpm</sub>	1800 <sub>rpm</sub>			
F	G	(H)	(I)	J										
7	12	—	—	9.5	0.52	0.44	0.36	0.30	0.26	0.24	0.21	0.02~0.14	0.0056	<b>AG0.5-20R1</b>
7	12	—	—	9.5	0.51	0.42	0.33	0.27	0.24	0.22	0.19	0.02~0.14	0.0056	<b>AG0.5-20R2</b>
7	12	—	—	12	1.09	0.94	0.77	0.65	0.58	0.53	0.48	0.02~0.14	0.012	<b>AG0.5-30R1</b>
7	12	—	—	12	1.09	0.92	0.73	0.60	0.54	0.49	0.43	0.02~0.14	0.012	<b>AG0.5-30R2</b>
7	12	—	—	14.5	1.86	1.60	1.34	1.15	1.02	0.94	0.84	0.02~0.14	0.020	<b>AG0.5-40R1</b>
7	12	—	—	17	2.82	2.42	2.05	1.77	1.58	1.46	1.30	0.02~0.14	0.035	<b>AG0.5-50R1</b>
7	12	—	—	19.5	3.94	3.41	2.89	2.50	2.26	2.08	1.87	0.02~0.14	0.053	<b>AG0.5-60R1</b>
8	16	—	—	14	1.78	1.50	1.21	1.00	0.88	0.82	0.71	0.06~0.17	0.018	<b>AG0.8-20R1</b>
8	16	—	—	14	1.76	1.44	1.11	0.91	0.80	0.74	0.63	0.06~0.17	0.018	<b>AG0.8-20R2</b>
8	16	—	—	18	3.77	3.21	2.62	2.20	1.96	1.81	1.61	0.06~0.17	0.043	<b>AG0.8-30R1</b>
8	16	—	—	18	3.75	3.14	2.46	2.02	1.80	1.65	1.45	0.06~0.17	0.043	<b>AG0.8-30R2</b>
8	16	—	—	22	6.45	5.49	4.55	3.87	3.46	3.19	2.83	0.06~0.17	0.068	<b>AG0.8-40R1</b>
8	16	—	—	26	9.75	8.31	6.94	5.94	5.34	4.96	4.38	0.06~0.17	0.10	<b>AG0.8-50R1</b>
8	16	—	—	30	13.6	11.7	9.77	8.39	7.63	7.05	6.27	0.06~0.17	0.14	<b>AG0.8-60R1</b>

- [Caution on Secondary Operations] ① Please read "Caution on Performing Secondary Operations" (Page 512) when performing modifications and/or secondary operations for safety concerns. Haguruma Kobo, the KHK's system for quick modification of KHK stock gears is also available.



Specifications	
Precision grade	KHK W 001 grade 2
Reference section of gear	Axial
Gear teeth	Standard full depth
Normal pressure angle	20°
Material	SCM440
Heat treatment	Thermal refined, tooth surface induction hardened
Tooth hardness	45 ~ 55HRC

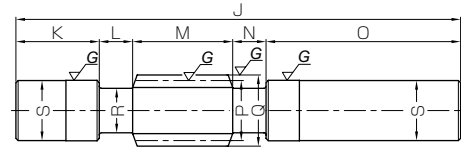

W6

Catalog No.	Axial module	Number of start	Lead angle	Hand of tread	Shape	Total length	Shaft length (L)	Neck length (L)	Face width	Neck length (R)	Shaft length (R)	Pitch dia.
						J	K	L	M	N	O	P
<b>KWG1-R1</b>	<b>m1</b>	1	3°35'	R	W6	140	35	10	30	10	55	16
<b>KWG1-R2</b>		2	7°08'	R	W6	140	35	10	30	10	55	16
<b>KWG1.5-R1</b>	<b>m1.5</b>	1	3°26'	R	W6	190	50	15	40	15	70	25
<b>KWG1.5-R2</b>		2	6°51'	R	W6	190	50	15	40	15	70	25

[Caution on Product Characteristics]

- ① For W6 Shaped Gears, the tolerances of the shaft diameter are set to S +0.2 and +0.1 (+0.40 and +0.35 for the ground area).
- ② These worms produce axial thrust forces. See page 512 for more details.



Specifications	
Precision grade	KHK W 002 grade 2
Reference section of gear	Rotating plane
Gear teeth	Standard full depth
Normal pressure angle	20°
Material	CAC702 (formerly JIS A&BC2)
Heat treatment	—
Tooth hardness	—

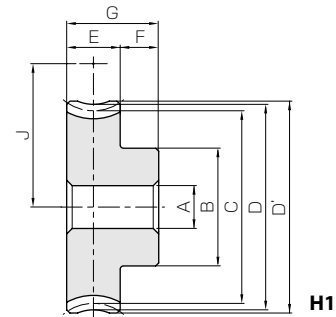

Catalog No.	Reduction ratio	Transverse module	No. of teeth	Number of start	Helix angle	Hand of tread	Shape	Bore	Hub dia.	Pitch dia.	Throat dia.	Outside dia.	Face width
								A <sub>H7</sub>	B	C	D	D'	E
<b>AG1-20R1</b>	20	<b>m1</b>	20	1	3°35'	R	H1	6	16	20	22	23	10
<b>AG1-20R2</b>	10		20	2	7°08'	R	H1	6	16	20	22	23	10
<b>AG1-30R1</b>	30		30	1	3°35'	R	H1	6	20	30	32	33	10
<b>AG1-30R2</b>	15		30	2	7°08'	R	H1	6	20	30	32	33	10
<b>AG1-40R1</b>	40		40	1	3°35'	R	H1	8	26	40	42	43	10
<b>AG1-50R1</b>	50		50	1	3°35'	R	H1	8	30	50	52	53	10
<b>AG1-60R1</b>	60	60	1	3°35'	R	H1	10	35	60	62	63	10	
<b>AG1.5-20R1</b>	20	<b>m1.5</b>	20	1	3°26'	R	H1	8	22	30	33	34.5	14
<b>AG1.5-20R2</b>	10		20	2	6°51'	R	H1	8	22	30	33	34.5	14
<b>AG1.5-30R1</b>	30		30	1	3°26'	R	H1	10	30	45	48	49.5	14
<b>AG1.5-30R2</b>	15		30	2	6°51'	R	H1	10	30	45	48	49.5	14
<b>AG1.5-40R1</b>	40		40	1	3°26'	R	H1	12	35	60	63	64.5	14
<b>AG1.5-50R1</b>	50		50	1	3°26'	R	H1	12	45	75	78	79.5	14
<b>AG1.5-60R1</b>	60	60	1	3°26'	R	H1	12	50	90	93	94.5	14	

[Caution on Product Characteristics]

- ① The allowable torques shown in the table are the calculated values according to the assumed usage conditions. Please see page 510 for more details.

Outside dia.	Neck dia.	Shaft dia.	Weight (kg)	Catalog No.
Q	R	S		
18	13	18	0.25	<b>KWG1-R1</b>
18	13	18	0.25	<b>KWG1-R2</b>
28	21	26	0.74	<b>KWG1.5-R1</b>
28	21	26	0.74	<b>KWG1.5-R2</b>

- [Caution on Secondary Operations] ① Please read "Caution on Performing Secondary Operations" (Page 512) when performing modifications and/or secondary operations for safety concerns. Haguruma Kobo, the KHK's system for quick modification of KHK stock gears is also available.
- ② Due to the gear teeth being induction hardened, no secondary operations can be performed on tooth areas including the bottom land (approx. 1 to 2 mm). Use carbide tools for the modification of the shaft area near the bottom land.

AG

## Worm Wheels



NOTE 1. Allowable torques for worm rotation (rpm)

Hub width	Total length	Web thickness	Web O.D.	Mounting distance	Allowable torque (N·m) NOTE 1							Backlash (mm)	Weight (kg)	Catalog No.
					30 <sub>rpm</sub>	100 <sub>rpm</sub>	300 <sub>rpm</sub>	600 <sub>rpm</sub>	900 <sub>rpm</sub>	1200 <sub>rpm</sub>	1800 <sub>rpm</sub>			
F	G	(H)	(I)	J										
10	20	—	—	18	3.35	2.79	2.23	1.83	1.63	1.50	1.30	0.08~0.19	0.038	<b>AG1-20R1</b>
10	20	—	—	18	3.31	2.69	2.06	1.68	1.48	1.35	1.15	0.08~0.19	0.038	<b>AG1-20R2</b>
10	20	—	—	23	7.08	5.98	4.84	4.05	3.63	3.31	2.92	0.08~0.19	0.078	<b>AG1-30R1</b>
10	20	—	—	23	7.03	5.84	4.56	3.72	3.33	3.03	2.63	0.08~0.19	0.078	<b>AG1-30R2</b>
10	20	—	—	28	12.1	10.2	8.43	7.12	6.38	5.86	5.13	0.08~0.19	0.13	<b>AG1-40R1</b>
10	20	—	—	33	18.3	15.5	12.9	10.9	9.87	9.09	7.95	0.08~0.19	0.20	<b>AG1-50R1</b>
10	20	—	—	38	25.6	21.8	18.1	15.4	14.1	12.9	11.4	0.08~0.19	0.29	<b>AG1-60R1</b>
10	24	—	—	27.5	9.84	8.18	6.40	5.30	4.68	4.25	3.68	0.10~0.21	0.10	<b>AG1.5-20R1</b>
10	24	—	—	27.5	9.72	7.87	5.92	4.87	4.25	3.83	3.27	0.10~0.21	0.10	<b>AG1.5-20R2</b>
10	24	—	—	35	20.8	17.5	13.9	11.7	10.4	9.40	8.28	0.10~0.21	0.22	<b>AG1.5-30R1</b>
10	24	—	—	35	20.7	17.1	13.1	10.8	9.56	8.58	7.46	0.10~0.21	0.22	<b>AG1.5-30R2</b>
10	24	—	—	42.5	35.6	30.0	24.2	20.6	18.3	16.6	14.6	0.10~0.21	0.37	<b>AG1.5-40R1</b>
10	24	—	—	50	53.8	45.4	36.9	31.6	28.3	25.8	22.6	0.10~0.21	0.59	<b>AG1.5-50R1</b>
10	24	—	—	57.5	75.3	63.8	51.9	44.7	40.4	36.7	32.4	0.10~0.21	0.83	<b>AG1.5-60R1</b>

- [Caution on Secondary Operations] ① Please read "Caution on Performing Secondary Operations" (Page 512) when performing modifications and/or secondary operations for safety concerns. Haguruma Kobo, the KHK's system for quick modification of KHK stock gears is also available.



Specifications	
Precision grade	KHK W 001 grade 2
Reference section of gear	Axial
Gear teeth	Standard full depth
Normal pressure angle	20°
Material	SCM440
Heat treatment	Thermal refined, tooth surface induction hardened
Tooth hardness	45 ~ 55HRC

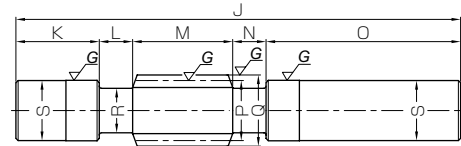

W6

Catalog No.	Axial module	Number of start	Lead angle	Hand of tread	Shape	Total length	Shaft length (L)	Neck length (L)	Face width	Neck length (R)	Shaft length (R)	Pitch dia.
						J	K	L	M	N	O	P
<b>KWG2-R1</b>	<b>m2</b>	1	5°12'	R	W6	200	35	25	40	25	75	22
<b>KWG2-R2</b>		2	10°18'	R	W6	200	35	25	40	25	75	22
<b>KWG2.5-R1</b>	<b>m2.5</b>	1	4°46'	R	W6	250	50	27	46	27	100	30
<b>KWG2.5-R2</b>		2	9°28'	R	W6	250	50	27	46	27	100	30

[Caution on Product Characteristics] ① For W6 Shaped Gears, the tolerances of the shaft diameter are set to S +0.2 and +0.1 (+0.40 and +0.35 for the ground area).  
 ② These worms produce axial thrust forces. See page 512 for more details.



Specifications	
Precision grade	KHK W 002 grade 2
Reference section of gear	Rotating plane
Gear teeth	Standard full depth
Normal pressure angle	20°
Material	CAC702 (formerly JIS A&BC2) *
Heat treatment	—
Tooth hardness	—

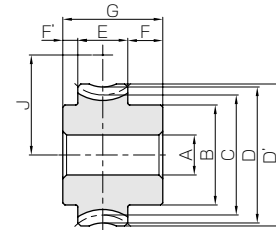

\* H8, H9 shape have a hub made from FC200 cast iron.

H6

Catalog No.	Reduction ratio	Transverse module	No. of teeth	Number of start	Profile shift coefficient	Helix angle	Hand of tread	Shape	Bore	Hub dia.	Pitch dia.	Throat dia.	Outside dia.	Face width	Hub width(R)
									AH7	B	C	D	D'	E	F
<b>AGF2-20R1</b>	20	<b>m2</b>	20	1	-0.5	5°12'	R	H6	12	32	40	42	44	18	12
<b>AGF2-20R2</b>	10		20	2	-0.5	10°18'	R	H6	12	32	40	42	44	18	12
<b>AGF2-25R1</b>	25		25	1	-0.5	5°12'	R	H6	12	35	50	52	54	18	12
<b>AGF2-30R1</b>	30		30	1	-0.5	5°12'	R	H6	12	38	60	62	64	18	12
<b>AGF2-30R2</b>	15		30	2	-0.5	10°18'	R	H6	12	38	60	62	64	18	12
<b>AGF2-36R1</b>	36		36	1	0	5°12'	R	H6	12	40	72	76	78	18	12
<b>AGF2-40R1</b>	40	40	1	-0.5	5°12'	R	H8	12	45	80	82	84	18	12	
<b>AGF2-48R1</b>	48	48	1	+0.5	5°12'	R	H9	12	50	96	102	104	18	12	
<b>AGF2-50R1</b>	50	50	1	-0.5	5°12'	R	H9	12	50	100	102	104	18	12	
<b>AGF2-60R1</b>	60	60	1	-0.5	5°12'	R	H9	12	50	120	122	124	18	12	
<b>AGF2.5-20R1</b>	20	<b>m2.5</b>	20	1	0	4°46'	R	H6	12	35	50	55	57.5	20	15
<b>AGF2.5-20R2</b>	10		20	2	0	9°28'	R	H6	12	35	50	55	57.5	20	15
<b>AGF2.5-20R2</b>	25		25	1	0	4°46'	R	H6	12	40	62.5	67.5	70	20	15
<b>AGF2.5-20R2</b>	30		30	1	0	4°46'	R	H6	12	40	75	80	82.5	20	15
<b>AGF2.5-20R2</b>	15		30	2	0	9°28'	R	H6	12	40	75	80	82.5	20	15
<b>AGF2.5-36R1</b>	36		36	1	0	4°46'	R	H8	12	45	90	95	97.5	20	15
<b>AGF2.5-40R1</b>	40	40	1	0	4°46'	R	H9	12	45	100	105	107.5	20	15	
<b>AGF2.5-48R1</b>	48	48	1	0	4°46'	R	H9	12	50	120	125	127.5	20	15	
<b>AGF2.5-50R1</b>	50	50	1	0	4°46'	R	H9	12	55	125	130	132.5	20	15	
<b>AGF2.5-60R1</b>	60	60	1	0	4°46'	R	H9	12	60	150	155	157.5	20	15	

[Caution on Product Characteristics] ① The allowable torques shown in the table are the calculated values according to the assumed usage conditions. Please see page 510 for more details.  
 ② There may be space in the casting between the two materials, but it will not affect the joint strength.

Outside dia.	Neck dia.	Shaft dia.	Weight (kg)	Catalog No.
Q	R	S		
26	17	25	0.64	<b>KWG2-R1</b>
26	17	25	0.64	<b>KWG2-R2</b>
35	23	30	1.27	<b>KWG2.5-R1</b>
35	23	30	1.27	<b>KWG2.5-R2</b>

- [Caution on Secondary Operations] ① Please read "Caution on Performing Secondary Operations" (Page 512) when performing modifications and/or secondary operations for safety concerns. Haguruma Kobo, the KHK's system for quick modification of KHK stock gears is also available.
- ② Due to the gear teeth being induction hardened, no secondary operations can be performed on tooth areas including the bottom land (approx. 1 to 2 mm). Use carbide tools for the modification of the shaft area near the bottom land.

AG

Worm Wheels

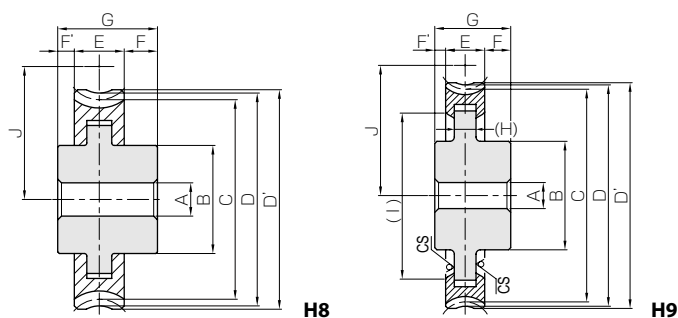

\* CS has a sand mold casting finish.

NOTE 1. Allowable torques for worm rotation (rpm)



Hub width	Total length	Web thickness	Web O.D.	Mounting distance	Allowable torque (N·m) NOTE 1							Backlash (mm)	Weight (kg)	Catalog No.
					30 rpm	100 rpm	300 rpm	600 rpm	900 rpm	1200 rpm	1800 rpm			
F	G	(H)	(I)	J										
5	35	—	—	30	19.4	16.1	12.8	10.5	9.30	8.49	7.31	0.11~0.24	0.25	<b>AGF2-20R1</b>
5	35	—	—	30	19.9	16.1	12.2	9.99	8.75	7.92	6.74	0.11~0.24	0.25	<b>AGF2-20R2</b>
5	35	—	—	35	29.4	24.5	19.6	16.3	14.4	13.2	11.4	0.11~0.24	0.37	<b>AGF2-25R1</b>
5	35	—	—	40	41.1	34.5	27.7	23.2	20.7	18.8	16.4	0.11~0.24	0.51	<b>AGF2-30R1</b>
5	35	—	—	40	42.3	35.0	27.0	22.1	19.9	17.7	15.4	0.11~0.24	0.51	<b>AGF2-30R2</b>
5	35	—	—	47	57.8	48.6	39.3	33.2	29.6	27.0	23.6	0.11~0.24	0.73	<b>AGF2-36R1</b>
5	35	—	—	50	70.3	59.2	48.1	40.7	36.4	33.2	28.9	0.11~0.24	0.85	<b>AGF2-40R1</b>
5	35	(10)	(76)	60	98.5	83.0	68.0	57.9	51.9	47.5	41.3	0.11~0.24	1.14	<b>AGF2-48R1</b>
5	35	(12)	(81)	60	106	89.5	73.4	62.5	56.2	51.5	44.9	0.11~0.24	1.14	<b>AGF2-50R1</b>
5	35	(12)	(96)	70	149	126	103	88.4	80.3	73.3	64.2	0.11~0.24	1.51	<b>AGF2-60R1</b>
5	40	—	—	40	35.1	29.0	22.6	18.6	16.3	14.8	12.8	0.14~0.27	0.44	<b>AGF2.5-20R1</b>
5	40	—	—	40	34.6	27.9	20.9	17.1	14.8	13.4	11.3	0.14~0.27	0.44	<b>AGF2.5-20R2</b>
5	40	—	—	46.25	53.0	43.9	34.8	28.9	25.3	23.0	20.0	0.14~0.27	0.66	<b>AGF2.5-25R1</b>
5	40	—	—	52.5	74.1	62.0	49.1	41.2	36.7	32.8	28.7	0.14~0.27	0.87	<b>AGF2.5-30R1</b>
5	40	—	—	52.5	73.6	60.6	46.2	37.8	33.2	29.9	25.8	0.14~0.27	0.87	<b>AGF2.5-30R2</b>
5	40	—	—	60	104	87.4	69.8	59.0	51.8	47.1	41.2	0.14~0.27	1.19	<b>AGF2.5-36R1</b>
5	40	(12)	(80)	65	127	106	85.4	72.4	63.7	57.9	50.5	0.14~0.27	1.23	<b>AGF2.5-40R1</b>
5	40	(13)	(97)	75	178	149	121	103	90.8	83.1	72.2	0.14~0.27	1.72	<b>AGF2.5-48R1</b>
5	40	(13)	(100)	77.5	192	161	130	111	98.4	90.0	78.3	0.14~0.27	1.92	<b>AGF2.5-50R1</b>
5	40	(13)	(125)	90	268	226	183	157	141	128	112	0.14~0.27	2.59	<b>AGF2.5-60R1</b>

- [Caution on Secondary Operations] ① Please read "Caution on Performing Secondary Operations" (Page 512) when performing modifications and/or secondary operations for safety concerns. Haguruma Kobo, the KHK's system for quick modification of KHK stock gears is also available.
- ② The tooth and the hub areas, fastened by casting, are designed to have higher hardness than other parts of the gear. However, please avoid areas other than the hub. Also, the strength may decrease if secondary operations are performed.



Specifications	
Precision grade	KHK W 001 grade 2
Reference section of gear	Axial
Gear teeth	Standard full depth
Normal pressure angle	20°
Material	SCM440
Heat treatment	Thermal refined, tooth surface induction hardened
Tooth hardness	45 ~ 55HRC

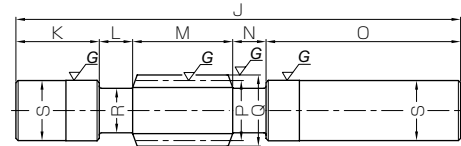

**W6**

Catalog No.	Axial module	Number of start	Lead angle	Hand of tread	Shape	Total length	Shaft length (L)	Neck length (L)	Face width	Neck length (R)	Shaft length (R)	Pitch dia.
						J	K	L	M	N	O	P
<b>KWG3-R1</b>	<b>m3</b>	1	4°31'	R	W6	300	55	30	60	30	125	38
<b>KWG3-R2</b>		2	8°58'	R	W6	300	55	30	60	30	125	38
<b>KWG4-R1</b>	<b>m4</b>	1	5°43'	R	W6	360	70	32.5	75	32.5	150	40
<b>KWG4-R2</b>		2	11°19'	R	W6	360	70	32.5	75	32.5	150	40

[Caution on Product Characteristics]

- ① For W6 Shaped Gears, the tolerances of the shaft diameter are set to S +0.2 and +0.1 (+0.40 and +0.35 for the ground area).
- ② These worms produce axial thrust forces. See page 512 for more details.



Specifications	
Precision grade	KHK W 002 grade 2
Reference section of gear	Rotating plane
Gear teeth	Standard full depth
Normal pressure angle	20°
Material	CAC702 (formerly JIS A&BC2) *
Heat treatment	—
Tooth hardness	—

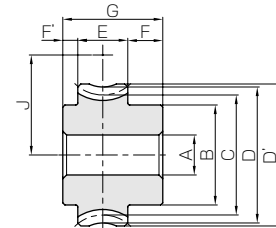

**H6**

\* H8, H9 shape have a hub made from FC200 cast iron.

Catalog No.	Reduction ratio	Transverse module	No. of teeth	Number of start	Profile shift coefficient	Helix angle	Hand of tread	Shape	Bore	Hub dia.	Pitch dia.	Throat dia.	Outside dia.	Face width	Hub width(R)
									AH7	B	C	D	D'	E	F
<b>AGF3-20R1</b>	20	<b>m3</b>	20	1	+0.333	4°31'	R	H6	20	50	60	68	71	25	17.5
<b>AGF3-20R2</b>	10		20	2	+0.333	8°58'	R	H6	20	50	60	68	71	25	17.5
<b>AGF3-25R1</b>	25		25	1	0	4°31'	R	H6	20	55	75	81	84	25	17.5
<b>AGF3-30R1</b>	30		30	1	+0.333	4°31'	R	H8	20	55	90	98	101	25	17.5
<b>AGF3-30R2</b>	15		30	2	+0.333	8°58'	R	H8	20	55	90	98	101	25	17.5
<b>AGF3-36R1</b>	36		36	1	+0.333	4°31'	R	H8	20	60	108	116	119	25	17.5
<b>AGF3-40R1</b>	40		40	1	+0.333	4°31'	R	H9	20	65	120	128	131	25	17.5
<b>AGF3-48R1</b>	48		48	1	+0.333	4°31'	R	H9	20	70	144	152	155	25	17.5
<b>AGF3-50R1</b>	50		50	1	+0.333	4°31'	R	H9	20	75	150	158	161	25	17.5
<b>AGF3-60R1</b>	60		60	1	+0.333	4°31'	R	H9	20	80	180	188	191	25	17.5
<b>AGF4-20R1</b>	20	<b>m4</b>	20	1	0	5°43'	R	H6	20	60	80	88	92	30	20
<b>AGF4-20R2</b>	10		20	2	0	11°19'	R	H6	20	60	80	88	92	30	20
<b>AGF4-25R1</b>	25		25	1	0	5°43'	R	H6	20	65	100	108	112	30	20
<b>AGF4-30R1</b>	30		30	1	0	5°43'	R	H8	20	65	120	128	132	30	20
<b>AGF4-30R2</b>	15		30	2	0	11°19'	R	H8	20	65	120	128	132	30	20
<b>AGF4-36R1</b>	36		36	1	0	5°43'	R	H9	20	70	144	152	156	30	20
<b>AGF4-40R1</b>	40		40	1	0	5°43'	R	H9	20	80	160	168	172	30	20
<b>AGF4-48R1</b>	48		48	1	0	5°43'	R	H9	20	90	192	200	204	30	20
<b>AGF4-50R1</b>	50		50	1	0	5°43'	R	H9	20	90	200	208	212	30	20
<b>AGF4-60R1</b>	60		60	1	0	5°43'	R	H0	160	—	240	248	252	30	7

[Caution on Product Characteristics]

- ① The allowable torques shown in the table are the calculated values according to the assumed usage conditions. Please see page 510 for more details.
- ② There may be space in the casting between the two materials, but it will not affect the joint strength.





Specifications	
Precision grade	KHK W 001 grade 2
Reference section of gear	Axial
Gear teeth	Standard full depth
Normal pressure angle	20°
Material	SCM440
Heat treatment	Thermal refined, tooth surface induction hardened
Tooth hardness	45 ~ 55HRC

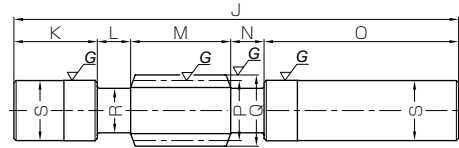

W6

Catalog No.	Axial module	Number of start	Lead angle	Hand of tread	Shape	Total length	Shaft length (L)	Neck length (L)	Face width	Neck length (R)	Shaft length (R)	Pitch dia.
						J	K	L	M	N	O	P
<b>KWG5-R1</b>	<b>m5</b>	1	5°43'	R	W6	400	75	30	90	30	175	50
<b>KWG6-R1</b>	<b>m6</b>	1	5°43'	R	W6	400	60	40	100	40	160	60

[Caution on Product Characteristics]

- ① For W6 Shaped Gears, the tolerances of the shaft diameter are set to S +0.2 and +0.1 (+0.40 and +0.35 for the ground area).
- ② These worms produce axial thrust forces. See page 512 for more details.



Specifications	
Precision grade	KHK W 002 grade 2
Reference section of gear	Rotating plane
Gear teeth	Standard full depth
Normal pressure angle	20°
Material	CAC702 (formerly JIS A&BC2) *
Heat treatment	—
Tooth hardness	—

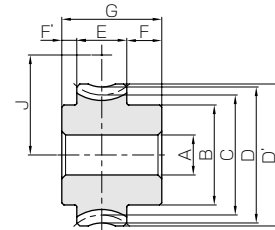

\* H8, H9 shape have a hub made from FC200 cast iron.

H6

Catalog No.	Reduction ratio	Transverse module	No. of teeth	Number of start	Profile shift coefficient	Helix angle	Hand of tread	Shape	Bore	Hub dia.	Pitch dia.	Throat dia.	Outside dia.	Face width	Hub width(R)
									AH7	B	C	D	D'	E	F
<b>AGF5-20R1</b>	20	<b>m5</b>	20	1	0	5°43'	R	H6	22	75	100	110	115	35	23
<b>AGF5-25R1</b>	25		25	1	0	5°43'	R	H6	22	75	125	135	140	35	23
<b>AGF5-30R1</b>	30		30	1	0	5°43'	R	H9	22	75	150	160	165	35	23
<b>AGF5-36R1</b>	36		36	1	0	5°43'	R	H9	22	90	180	190	195	35	23
<b>AGF5-40R1</b>	40		40	1	0	5°43'	R	H9	22	110	200	210	215	35	23
<b>AGF5-48R1</b>	48		48	1	0	5°43'	R	H0	140	—	240	250	255	35	7.5
<b>AGF5-50R1</b>	50	50	1	0	5°43'	R	H0	150	—	250	260	265	35	7.5	
<b>AGF5-60R1</b>	60	60	1	0	5°43'	R	H0	200	—	300	310	315	35	7.5	
<b>AGF6-20R1</b>	20	<b>m6</b>	20	1	0	5°43'	R	H6	25	85	120	132	138	40	23
<b>AGF6-25R1</b>	25		25	1	0	5°43'	R	H6	25	90	150	162	168	40	23
<b>AGF6-30R1</b>	30		30	1	0	5°43'	R	H9	25	100	180	192	198	40	23
<b>AGF6-36R1</b>	36		36	1	0	5°43'	R	H9	25	110	216	228	234	40	23
<b>AGF6-40R1</b>	40		40	1	0	5°43'	R	H0	130	—	240	252	258	40	8
<b>AGF6-48R1</b>	48		48	1	0	5°43'	R	H0	180	—	288	300	306	40	8
<b>AGF6-50R1</b>	50	50	1	0	5°43'	R	H0	190	—	300	312	318	40	8	
<b>AGF6-60R1</b>	60	60	1	0	5°43'	R	H0	250	—	360	372	378	40	8	

[Caution on Product Characteristics]

- ① The allowable torques shown in the table are the calculated values according to the assumed usage conditions. Please see page 510 for more details.
- ② There may be space in the casting between the two materials, but it will not affect the joint strength.

Outside dia.	Neck dia.	Shaft dia.	Weight (kg)	Catalog No.
Q	R	S		
60	36	50	5.75	<b>KWG5-R1</b>
72	44	60	8.09	<b>KWG6-R1</b>

- [Caution on Secondary Operations] ① Please read "Caution on Performing Secondary Operations" (Page 512) when performing modifications and/or secondary operations for safety concerns. Haguruma Kobo, the KHK's system for quick modification of KHK stock gears is also available.
- ② Due to the gear teeth being induction hardened, no secondary operations can be performed on tooth areas including the bottom land (approx. 1 to 2 mm). Use carbide tools for the modification of the shaft area near the bottom land.

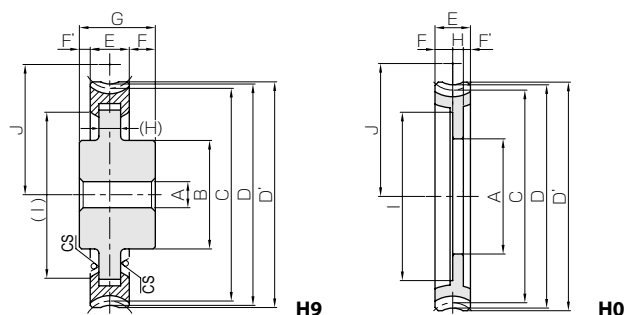

\* CS has a sand mold casting finish.

NOTE 1. Allowable torques for worm rotation (rpm)



Hub width (L)	Total length	Web thickness	Web O.D.	Mounting distance	Allowable torque (N·m) NOTE 1							Backlash (mm)	Weight (kg)	Catalog No.
					30 <sub>rpm</sub>	100 <sub>rpm</sub>	300 <sub>rpm</sub>	600 <sub>rpm</sub>	900 <sub>rpm</sub>	1200 <sub>rpm</sub>	1800 <sub>rpm</sub>			
F'	G	(H)	(I)	J										
12	70	—	—	75	211	172	134	108	95.0	86.2	72.7	0.22~0.35	3.26	<b>AGF5-20R1</b>
12	70	—	—	87.5	319	261	206	168	147	134	114	0.22~0.35	4.48	<b>AGF5-25R1</b>
12	70	(25)	(115)	100	446	369	291	239	211	191	164	0.22~0.35	5.37	<b>AGF5-30R1</b>
12	70	(25)	(140)	115	627	519	414	343	302	274	234	0.22~0.35	7.70	<b>AGF5-36R1</b>
12	70	(26)	(162)	125	763	632	506	421	371	337	288	0.22~0.35	9.97	<b>AGF5-40R1</b>
17.5	35	10	195	145	1070	886	715	598	530	483	411	0.22~0.35	5.04	<b>AGF5-48R1</b>
17.5	35	10	205	150	1150	956	772	646	574	523	446	0.22~0.35	5.28	<b>AGF5-50R1</b>
17.5	35	10	255	175	1610	1340	1090	913	820	744	639	0.22~0.35	6.48	<b>AGF5-60R1</b>
12	75	—	—	90	329	268	208	167	146	131	110	0.24~0.37	4.95	<b>AGF6-20R1</b>
12	75	—	—	105	497	405	319	259	227	204	173	0.24~0.37	7.14	<b>AGF6-25R1</b>
12	75	(30)	(135)	120	696	572	451	368	325	290	248	0.24~0.37	9.21	<b>AGF6-30R1</b>
12	75	(30)	(172)	138	978	806	641	528	466	417	355	0.24~0.37	12.5	<b>AGF6-36R1</b>
20	40	12	190	150	1190	981	784	648	572	513	436	0.24~0.37	6.20	<b>AGF6-40R1</b>
20	40	12	240	174	1670	1380	1110	920	816	735	628	0.24~0.37	7.58	<b>AGF6-48R1</b>
20	40	12	250	180	1800	1480	1200	994	885	796	676	0.24~0.37	8.00	<b>AGF6-50R1</b>
20	40	12	310	210	2520	2090	1680	1410	1260	1130	969	0.24~0.37	10.0	<b>AGF6-60R1</b>

- [Caution on Secondary Operations] ① Please read "Caution on Performing Secondary Operations" (Page 512) when performing modifications and/or secondary operations for safety concerns. Haguruma Kobo, the KHK's system for quick modification of KHK stock gears is also available.
- ② The tooth and the hub areas, fastened by casting, are designed to have higher hardness than other parts of the gear. However, please avoid areas other than the hub. Also, the strength may decrease if secondary operations are performed.