

Worm Gear Pair

Catalog Number of KHK Stock Gears

The Catalog Number for KHK stock gears is based on the simple formula listed below. Please order KHK gears by specifying the Catalog Numbers.

(Example) Worm Gear Pair

Worms

K W G DL 2 - R1

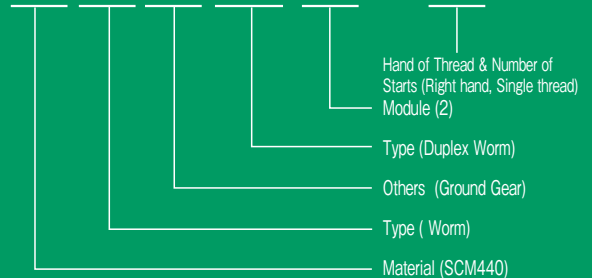

Material

K SCM440
S S45C
SU SUS303

Type

W Worms
DL Duplex Worms

Other Information

G Ground Gears
S Worm Shafts

Worm Wheels

A G 1.5 - 20 R2

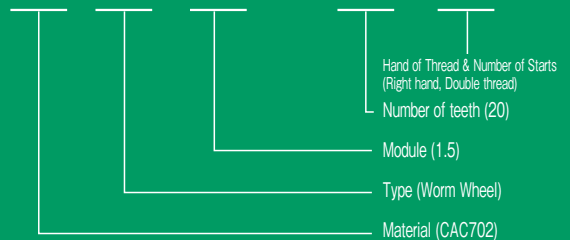

Material

A CAC702(*AlBC2)
B CAC502(*PBC2)
C FC200
D Polyacetal
P MC901

Type

G Worm Wheels
GDL Duplex Worm Wheels

* () indicates old JIS designation

KWGD L · KWGDLS Duplex Worms m1.5 ~ 4 Page 516 RoHS, H, G, B	AGDL Duplex Worm Wheels Reduction Ratio 20 ~ 60 m1.5 ~ 4 Page 516 RoHS, H, CAC	KWG Ground Worm Shafts m0.5 ~ 6 Page 522 RoHS, H, G, B
AG Worm Wheels Reduction Ratio 10 ~ 60 m0.5 ~ 1.5 Page 522 RoHS, H, CAC	AGF Worm Wheels Reduction Ratio 10 ~ 60 m2 ~ 6 Page 526 RoHS, H, CAC	SWG Ground Worms <i>J Series</i> Newly added m1 ~ 6 Page 532 RoHS, H, G, B
AG Worm Wheels Reduction Ratio 10 ~ 60 m1 ~ 6 Page 532 RoHS, H, CAC	SW Steel Worms <i>J Series</i> Newly added m0.5 ~ 6 Page 540 RoHS, H, B	BG Bronze Worm Wheels Reduction Ratio 10 ~ 60 m0.5 ~ 6 Page 540 RoHS, H, CAC
CG Gray Iron Worm Wheels Reduction Ratio 10 ~ 120 m1 ~ 6 Page 542 RoHS, H	SUW Stainless Steel Worms <i>J Series</i> Newly added m0.5 ~ 3 Page 556 RoHS, H, SUS	DG Plastic Worm Wheels Reduction Ratio 10 ~ 60 m0.5, 0.8 Page 556 RoHS, H, EP
PG Plastic Worm Wheels Reduction Ratio 10 ~ 50 m1 ~ 3 Page 558 RoHS, H, EP		

Feature Icons

RoHS Compliant Product	Stainless Product
Re-machinable Product	Resin Product
Finished Product	Copper Alloy Product
Heat Treated Product	Injection Molded Product
Ground Gear	Black Oxide coated Products

Spur Gears

Helical Gears

Internal Gears

Racks

CP Racks & Pinions

Miter Gears

Bevel Gears

Screw Gears

Worm Gear Pair

Bevel Gearboxes

Other Products

Bevel Gearboxes

Other Products



Worm Gear Pair

Characteristics



The simplest way to obtain a large speed reduction with high torque in a compact space is with worm gear drives. KHK stock worms and worm wheels are available in modules 0.5 to 6 and in speed ratios of 1/10 to 1/120, made in a variety of materials and styles. We also offer stock duplex worms and worm wheels with which you can obtain a very low backlash, high rotational precision system. The following table lists the main features for easy selection.

Type	Catalog No.	Module	No. of threads or reduction ratio	Material () JIS	Heat treatment	Tooth surface finish	Precision KHK W 001 KHK W 002 NOTE 2	Features	
Duplex Worms & Worm Wheels	Worm	KWGD L	2 ~ 4	Single thread	SCM440	Thermal refined, gear teeth induction hardened	Ground	1	High-precision duplex worms with superior strength. A range of backlash values can be obtained by moving the worm axially.
	Worm	KWGD LS	1.5 ~ 4	Single thread	SCM440	Thermal refined, gear teeth induction hardened	Ground	1	Duplex worms with a shaft, excellent in accuracy and strength. A range of backlash values can be obtained by moving the worm axially.
	Worm Wheel	AGD L	1.5 ~ 4	20 ~ 60	CAC702 (A)BC2	—	Cut	1	Duplex worm wheels made of aluminum bronze, excellent in wear-resistance. The pitch accuracy is first grade.
Worms & Worm Wheels	Worm	KWG	0.5 ~ 6	Single thread - Double thread	SCM440	Thermal refined, gear teeth induction hardened	Ground	2	Grounded finished worms with a shaft, including tooth surface quenching treatment. Allows compact design due to having small reference diameters.
	Worm Wheel	AG NOTE 1	0.5 ~ 1.5	10 ~ 60	CAC702 (A)BC2	—	Cut	2	Made of aluminum bronze, have excellent wear-resistance. Wide selection is available for this item.
	Worm Wheel	AGF NOTE 1	2 ~ 6	10 ~ 60	CAC702 (A)BC2	—	Cut	2	Made of aluminum bronze, have excellent wear-resistance. Allows compact design.
	Worm	SWG	1 ~ 6	Single thread - Triple thread	S45C	Gear teeth induction hardened	Ground	2	Reasonably priced ground worms. Ready-to-use finished products from the J Series, are also available.
	Worm Wheel	AG NOTE 1	1 ~ 6	10 ~ 60	CAC702 (A)BC2	—	Cut	2	Made of aluminum bronze, have excellent wear-resistance. Wide selection is available for this item.
	Worm	SW	0.5 ~ 6	Single thread - Double thread	S45C	—	Cut (Thread rolled)	4	Economical, commonly used worms that have broad utility. Ready-to-use finished products from the J Series are also available.
	Worm	SUW	0.5 ~ 3	Single thread - Double thread	SUS303	—	Cut	4	Rust-resistant worms made of stainless steel suitable for mating with DS or PG worm wheels. Finished products for the J Series are also available.
	Worm Wheel	BG	0.5 ~ 6	10 ~ 60	CAC502 (P)BC2	—	Cut	4	Phosphorous bronze worm wheels have excellent wear resistance. Interchangeable with CG Worm Wheels, and enhances strength.
	Worm Wheel	CG	1 ~ 6	10 ~ 120	FC200	—	Cut	4	Economical, commonly used worm wheels that have broad utility. Available with a large selection of modules and number of teeth.
	Worm Wheel	DG	0.5 ~ 0.8	10 ~ 60	Polyacetal	—	Cut	5	Fine pitch worm wheels made of polyacetal, a stable plastic material.
	Worm Wheel	PG	1 ~ 3	10 ~ 50	MC901	—	Cut	5	Light weight and strong MC Nylon worm wheels. Suitable for use in food machinery, and can be used without lubricant.

(NOTE 1) The material of cast hubs for AGF and AG worm wheels is FC200(Cast Iron). AG worm wheels mate primarily with SWG worms. But, for Modules 0.8 or smaller, AG worm wheels mate with KWG worms.

(NOTE 2) KHK stock worms and worm wheels are produced to KHK's own precision grades. See the "Precision of Worms and Worm Wheels" in the "Selection Hints" section.

Our precision gear cutting technology enables acceleration and noise reduction

Setting the proper tooth contact and the backlash is essential for using worm gears. Use KHK stock worm gears for safe, reliable use.



Worm Grinding Machine by Klingelnberg



Worm gear testing machine by Klingelnberg

1. Efficiency of Worm Gear Pair

The efficiency of power transmission varies somewhat with the conditions of assembly and lubricant, but is generally 30-90% (excludes losses from bearings and churning of lubricants). The efficiency of KHK stock worm gear pair is given below as a reference. To learn more about strength calculation, please refer to the technical information contained in the "Surface Durability of Cylindrical Worm Gearing" section on page 688.

■ Efficiency of KWGDLS/AGDL Worm Gear Pair (%)

(rpm = Rotation of worm)

Catalog No. \ Worm rpm	100	300	600	900	1200	1800
KWGD1.5-R1	35	42	47	51	53	57
KWGD2-R1	38	45	51	55	56	61
KWGD2.5-R1	40	48	54	57	60	63
KWGD3-R1	41	49	55	58	62	65
KWGD3.5-R1	42	50	56	61	62	65
KWGD4-R1	42	51	56	61	63	67

■ Efficiency of KWG/AG, AGF Worm Gear Pair (%)

(rpm = Rotation of worm)

Catalog No. \ Worm rpm	100	300	600	900	1200	1800
KWG0.5-R1	30	34	38	41	43	46
KWG0.8-R1	35	40	44	47	49	53
KWG1-R1	34	40	45	48	51	54
KWG1.5-R1	35	42	47	51	53	57
KWG2-R1	45	51	56	60	62	65
KWG2.5-R1	44	51	57	61	62	67
KWG3-R1	44	52	58	61	64	67
KWG4-R1	50	58	64	66	70	72
KWG5-R1	51	60	66	69	71	73
KWG6-R1	53	61	66	70	72	75
KWG0.5-R2	46	50	54	58	60	63
KWG0.8-R2	51	56	61	64	66	69
KWG1-R2	51	56	62	64	67	70
KWG1.5-R2	52	59	64	67	69	73
KWG2-R2	61	67	71	74	76	78
KWG2.5-R2	60	67	72	75	76	80
KWG3-R2	61	68	73	75	78	80
KWG4-R2	66	73	77	79	82	84

■ Efficiency of SW, SUM / CG, BG, PG Worm Gear Pair (%)

The efficiency is approximately as follows, depending on the assembly, loading, lubrication and rotational speed.

Catalog No.	Thread	Efficiency (%)
SW/SUW	Single thread	40 ~ 50%
	Double thread	50 ~ 60%

■ Efficiency of SWG/AG Worm Gear Pair (%)

(rpm = Rotation of worm)

Catalog No. \ Worm rpm	100	300	600	900	1200	1800
SWG1-R1	34	40	45	48	51	54
SWG1.5-R1	35	42	47	51	53	57
SWG2-R1	38	45	51	55	56	61
SWG2.5-R1	40	48	54	57	60	63
SWG3-R1	41	49	55	58	62	65
SWG4-R1	42	51	56	61	63	67
SWG5-R1	46	54	60	64	66	70
SWG6-R1	48	57	64	66	68	73
SWG1-R2	51	56	62	64	67	70
SWG1.5-R2	52	59	64	67	69	73
SWG2-R2	55	62	67	70	72	75
SWG2.5-R2	57	64	69	72	75	77
SWG3-R2	58	66	71	73	76	78
SWG4-R2	59	67	72	75	77	80
SWG5-R2	62	70	75	78	79	82
SWG6-R2	65	72	77	80	81	84
SWG3-R3	67	74	78	80	82	84
SWG4-R3	68	75	79	82	83	86

2. Self-Locking Feature of Worm Gear Pair

Self-locking is defined as the inability of worm wheels to drive the worms. Factors affecting the self-locking feature include the materials of the worm and worm wheel, lead angle, precision of manufacture, types of bearings, lubricant, etc. Thus, it is not dependent simply on the lead angle. But, in general, self-locking will occur when the lead angle in a single thread worm is less than 4°. For systems requiring fail-safe prevention of back drive, we recommend other braking mechanisms or one-way clutches.

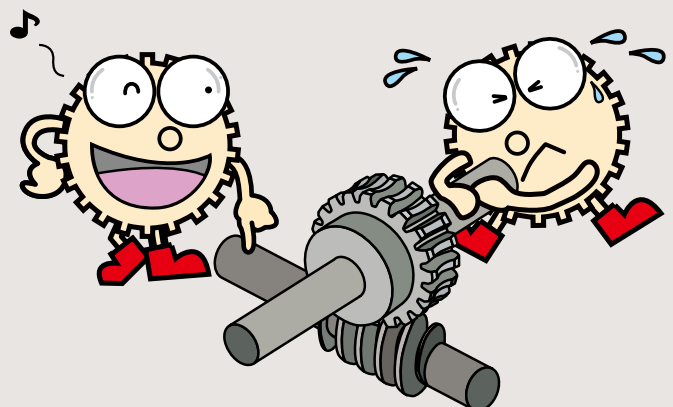



Worm Gear Pair

Selection Hints



Please select the most suitable products by carefully considering the characteristics of items and contents of the product tables. It is also important to read all applicable "CAUTION" notes shown below before the final selection. Use of catalog numbers when ordering will simplify and expedite the processing of your order.

1. Caution in Selecting the Mating Gears

Worms and worm wheels have either right-hand or left-hand helix. The same hand worms and worm wheels comprise sets. However, the number of threads and whether they use normal module or axial module system must also be matched. The table below shows available combinations of KHK stock worms and worm wheels.

Mating Worm Wheels Selection Chart

Worm	Mating Worm Wheel NOTE 1	Helix/ Thread	KWGDL KWGDLS			KWG			SWG			SW				SUW	
			R1	R1	R2	R1	R2	R3	R1	R2	L1	L2	R1	R2			
AGDL		R1	○														
AG0.5~1.5		R1		○													
AGF		R2			○												
AG		R1				○											
		R2					○										
		R3						○									
BG		R1							○							○	
		R2								○							
		L1									○						
		L2										○					
CG		R1									○					○	
		R2										○					
		L1											○				
		L2												○			
PG		R1										○				○	
		R2											○				
DG		R1												○		○	
		R2													○		

(NOTE 1) Select the same module for both members.

2. Caution in Selecting Gears Based on Gear Strength

The gear strength values shown in the product pages were computed by assuming a certain application environment as shown below. Therefore, they should be used as reference only. We recommend that each user computes their own values by applying the actual usage conditions.

Calculation assumptions for Surface Durability

Calculation assumptions for Bending Strength

Item	Catalog No.	KWGDL · KWGDLS/AGDL KWG/AGF, SWG/AG	SW/BG	SW/CG	SUW/PG	SUW/DG	
Formula NOTE 2		Formula of worm gear's strength (JGMA405-01)			The Lewis formula		
Rotations of worm		600rpm	100rpm		Allowable bending stress (kgf/mm ²)		
Lubricant		Lubricant for gears with proper viscosity and with anti-pressure additives				1.15 (40°C with No Lubrication)	NOTE 3 1 (40°C with No Lubrication)
Lubrication		Oil bath					
Starting condition		Starting torque less than 200% of rated torque. Less than 2 starts per hour					
Durability		26000 hours					
Impact from motor		Uniform load					
Impact from load		Uniform load					
Allowable stress factor Sc _{lim}		0.67	0.70	0.42			

(NOTE 2) The gear strength formula is based on JGMA (Japanese Gear Manufacturer's Association) specifications and "MC Nylon Technical Data" by Nippon Polyenco Limited. The units for the rotational speed (rpm) and the stress (kgf/mm²) are adjusted to the units needed in the formula.

(NOTE 3) Allowable bending stress of DG worm wheel is the value we estimated.

The Maximum Allowable Sliding Speed Due to Heat

The maximum allowable sliding speed for each series of worm wheels is given on the right. Select the appropriate part by calculating the sliding speed.

Sliding speed v_s (m/s)

$$v_s = \frac{dn}{19100 \cos \gamma}$$

d : Worm pitch dia.
 n : Worm speed (rpm)
 γ : Worm nominal lead angle

Catalog No.	Max. Sliding Speed (m/s)
AGDL	* 15
AGF	* 15
AG	* 15
BG	* 10
CG	* 2.5
PG	1 (no lubrication)

* JGMA405-01

The Helixes of Worms and Worm Wheels

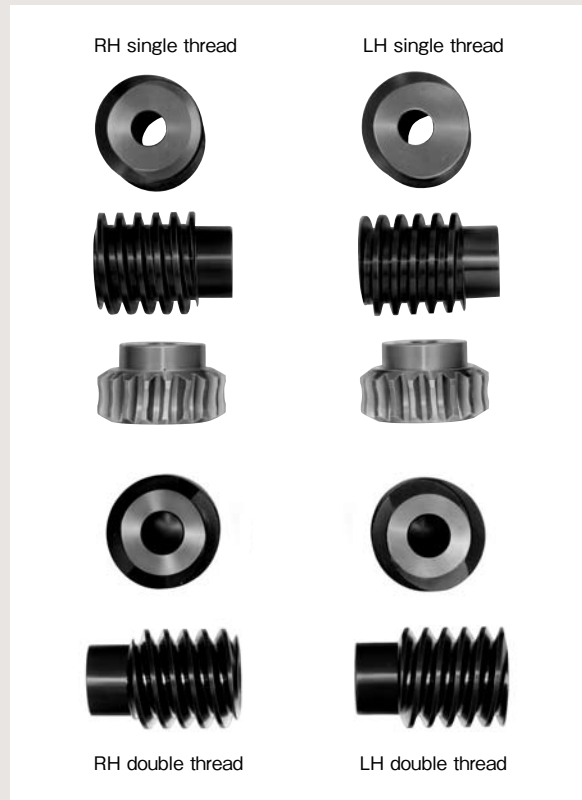

3. Selecting Worms and Worm Wheels by Precision

The precision standards of KHK stock worms and worm wheels are established by us. The table below indicates the tolerance ranges for our products.

① Precision of worms (KHK W 001)

KHK established allowable profile and lead errors of worms with precision grades 1 to 4, by using the JIS Standard as reference. Lead errors are measured over one full revolution.

■ Precision Grades of Worms (KHK W 001) (Unit: μm)

Grade	Error	Module				
		over <i>m</i> 0.4 up to 1	over <i>m</i> 1 up to 1.6	over <i>m</i> 1.6 up to 2.5	over <i>m</i> 2.5 up to 4	over <i>m</i> 4 up to 6
1	Tooth profile error	8	12	16	20	25
	Lead error	7	9	11	13	16
2	Tooth profile error	12	16	20	24	29
	Lead error	15	18	21	25	28
3	Tooth profile error	16	23	30	37	50
	Lead error	20	23	27	33	37
4	Tooth profile error	20	30	40	50	70
	Lead error	30	32	38	46	52

② Precision of worm wheels (KHK W 002)

We have established standard grades 1 to 5 of worm wheels using the JIS Standard as reference. The allowable values of Single Pitch Error and Runout Error are defined for each module size and pitch diameter.

■ Precision Grades of Worm Wheels (KHK W 002)

Unit : μm

Grade	Error	Over <i>m</i> 0.4 up to 1		Over <i>m</i> 1 up to 1.6			Over <i>m</i> 1.6 up to 2.5			Over <i>m</i> 2.5 up to 4			Over <i>m</i> 4 up to 6													
		Pitch diameter (mm)										25 up to 50	50 up to 100	100 up to 200	200 up to 400	400 up to 800										
		6 up to 12	12 up to 25	25 up to 50	50 up to 100	100 up to 200	12 up to 25	25 up to 50	50 up to 100	100 up to 200	200 up to 400															
1	Single pitch error	5	6	7	7	9	6	7	8	9	10	7	7	8	9	11	8	9	10	11	13	9	10	11	13	14
	Total composite error	21	24	26	30	34	25	28	31	35	41	27	30	33	37	43	33	36	40	46	53	37	40	45	50	57
2	Single pitch error	8	8	9	10	12	9	10	11	12	14	9	10	12	13	15	11	13	14	16	18	13	14	16	18	20
	Total composite error	30	33	37	42	48	35	39	44	50	57	38	42	46	52	60	46	51	57	64	74	52	57	63	71	80
3	Single pitch error	11	12	13	15	17	12	14	16	18	20	13	15	16	19	21	16	18	20	23	26	19	20	22	25	29
	Total composite error	43	47	53	60	68	50	55	62	71	81	53	59	66	74	85	65	72	81	91	105	74	81	90	100	115
4	Single pitch error	15	17	19	21	24	18	19	22	25	29	19	21	23	26	30	23	25	28	32	37	26	28	32	35	40
	Total composite error	60	66	74	83	95	70	77	87	99	115	75	83	92	105	120	91	100	115	130	145	105	115	125	140	160
5	Single pitch error	21	24	26	30	34	25	28	31	35	41	27	30	33	37	43	33	36	40	46	53	37	40	45	50	57
	Total composite error	86	94	105	120	135	100	110	125	140	165	105	120	130	150	170	130	145	160	185	210	150	160	180	200	230

③ Overall Length Tolerance of Worms

■ Overall Length Tolerance of Worms

Series	Total length(mm)	Tolerance
KWGDL	Uniform	0 - 0.10
		0 - 0.15
SWG SW SUW	Less than 100	0 - 0.15
	Over 100	0 - 0.20
KWGDLS KWG	Uniform	Normal tolerance

■ Overall Length Tolerance of Worms Wheels

Total length(mm)	Tolerance
below 30	0 - 0.10
over 30 up to 100	0 - 0.15
over 100	0 - 0.20

[CAUTION] PG Plastic Wheels are excluded.



Worm Gear Pair

Application Hints



In order to use KHK stock worms and worm wheels safely, carefully read the Application Hints before proceeding. If there are questions or you require clarifications, please contact our technical department or your nearest distributor.

KHK Co., Ltd.
TEL.048-254-1744 FAX.048-254-1765
E-mail export@khkgears.co.jp

1. Caution on Performing Secondary Operations

- ① If you are reboring, it is important to pay special attention to locating the center in order to avoid runout. (Fig.1) The reference datum for gear cutting or grinding is the bore. (For worm shafts, it is ground portion of the shaft.) Therefore, use the bore or shaft for locating the center. If it is too difficult to do for small bores, the alternative is to use one spot on the bore and the runout of the side surface.

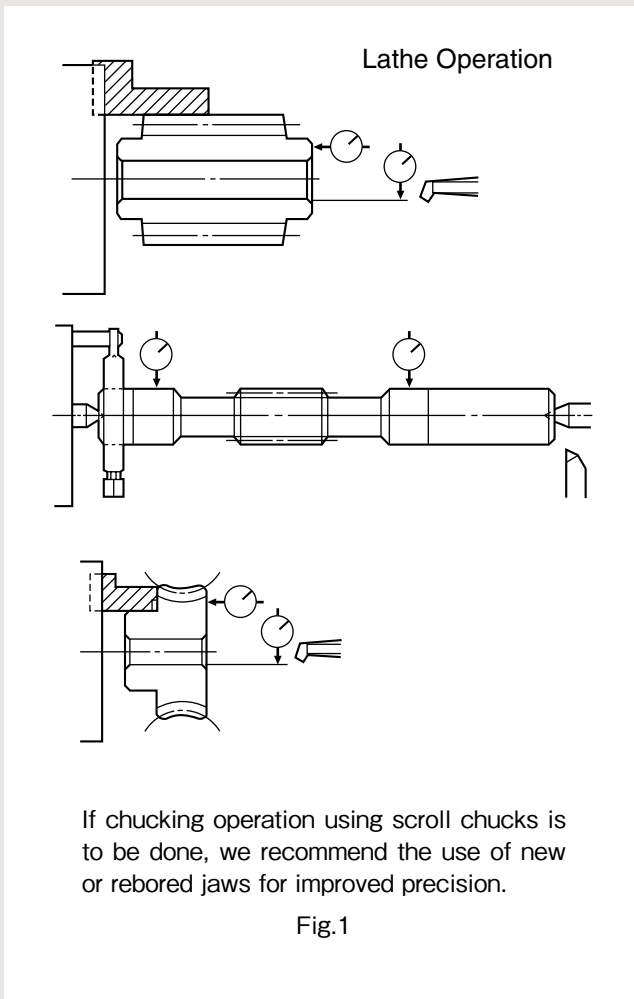

- ② To open up the bore to its maximum, calculate the bore size so that the tooth strength is weaker than the strength of the remaining material. For machining the maximum bore diameter, it should be designed so that the thickness between hub diameter (or root diameter) to bore diameter has more strength than the gear strength. As a guide, the maximum machined bore diameter should be within 60 % to 70 % of the hub diameter (or root diameter).

When the keyway is processed, it should be 50 % to 60 % . In the case FC material is used, it should be lower by 10% or more.

- ③ Since worm wheels are molded products, they may have air bubbles inside the material. In case you find air bubbles inside when performing secondary operations, and if the bubbles are found to be troublesome, please contact your KHK distributor.

2. Points of Caution in Assembling

- ① KHK stock worms and worm wheels are designed such that when assembled according to the specified mounting distance with a tolerance of H7 to H8, the backlash shown in the product tables is obtained. Do not attempt to eliminate backlash by pushing worms into worm wheels or operate with the worm shifted in the direction along the tooth.
- ② Because of the helix of the gear teeth, worms and worm wheels produce axial thrust forces. The directions of thrust depend on the hand of the helix and the direction of rotation. This is illustrated below in Fig.2. The bearings must be selected properly to be able to handle these thrust forces. See the "Gear Forces" section in the technical reference for more details (Page 699).

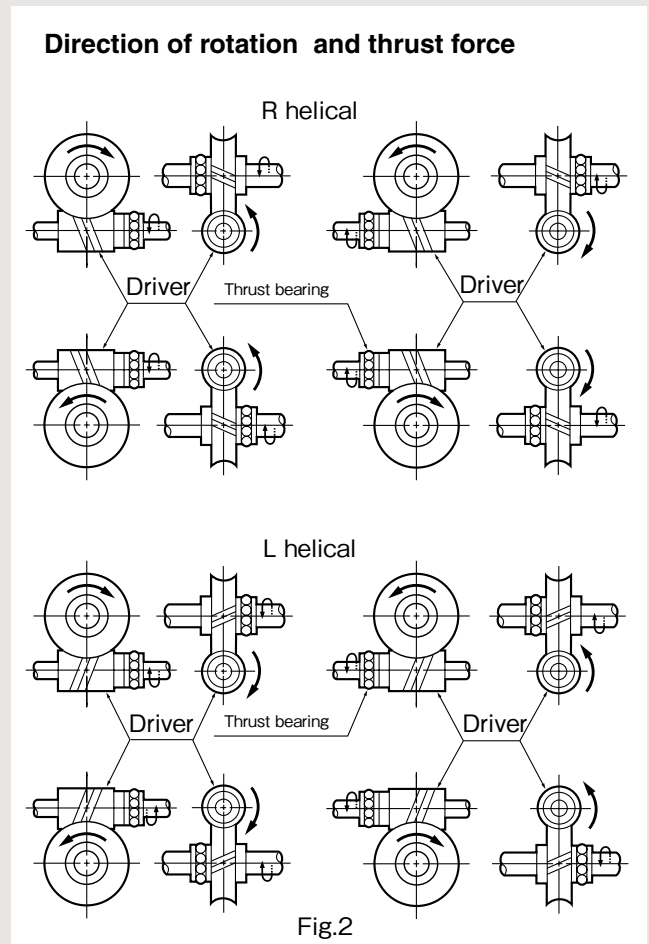

- ③ Because large thrust forces act on worms, if they are not secured to the shaft firmly, they tend to shift. Use of step shafts, set screws, dowel pins, etc., are recommended. Also, check for loosening of bearings due to thrust forces.

3. Verifying the orientation of assembly

How well the worms and worm wheels are assembled has large effects on the friction of the unit. The tooth contact at the time of assembly must be checked for correctness as shown below. See the "Tooth Contact of a Worm Gear Pair" section in the technical reference for more details (Page 659).

- Verify that the worm axis is perpendicular to the worm wheel axis.

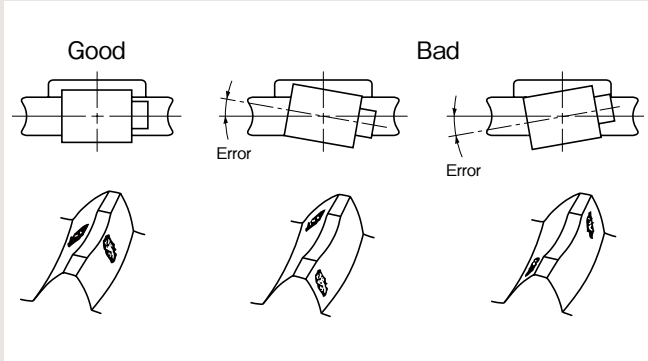

- Check that the worm axis is in the center of the worm wheel face width.

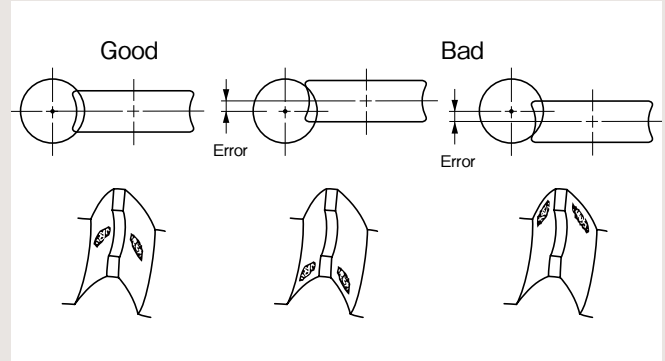

- Check the mounting distance (allowable mounting distance H7 ~ H8).

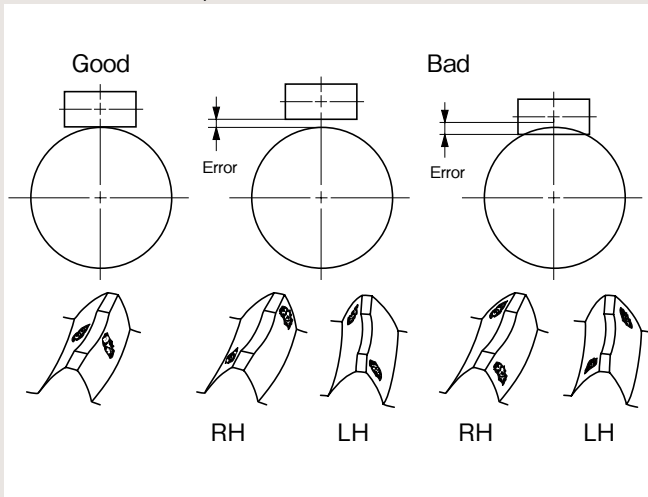

- Confirm that the center of the worm wheel goes through the midpoint of the worm length.

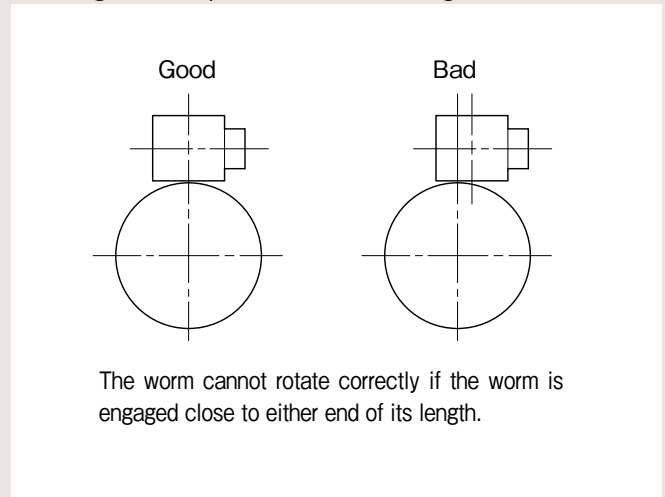

Application Examples

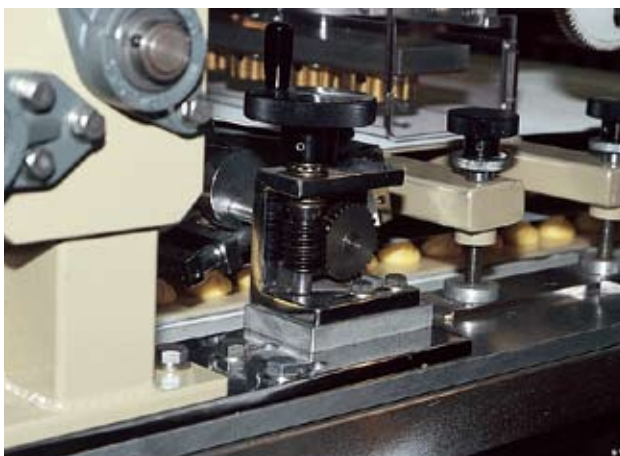

SW Worms and CG Worm Wheels used in a rotating comb device



SW Worms and BG Worm Wheels used in adjusting a cloth feeding device



Description of duplex worm gears

The usual method of adjusting the backlash of a worm gear assembly is to modify the center distance. Once assembled, such adjustment requires a major rework of the gearbox housing. The use of duplex worm gears allows the backlash adjustment to be made by axially shifting the worm. This simplifies greatly the assembly and maintenance operations. Because of the unique characteristics of the product, please take time to study its construction and proper use.

Backlash adjustment mechanism and method of adjustment

The dual-lead worm is formed to give a difference between the right tooth surface and left tooth surface so that it provides a unique tooth profile in which the tooth thickness varies continuously, corresponding with the lead difference. (Fig.1)

The worm gear is also formed in its right and left tooth surface.

When such a worm and worm gear are set up at a constant assembly distance and the worm is moved in the axial direction, the tooth thickness of the worm in mesh with the worm gear changes making backlash adjustment possible.



An arrow marking on the outer circumference of the hub of the KHK duplex worm indicates the direction of assembly as well as acts as a guide for the backlash adjustment.

When the worm is held with arrow mark pointing right, the tooth thickness is thinner on the right and thicker on the left. Therefore, moving the worm to the right causes the thicker teeth to come into actual engagement with the worm gear, thereby reducing the backlash. (Fig.2)

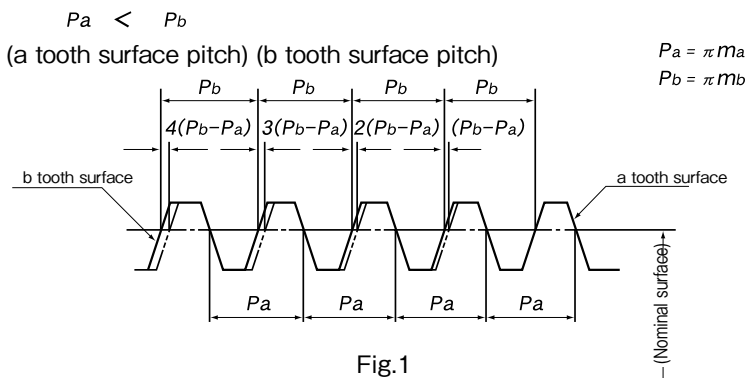

(CAUTION) The amount of change in backlash (Δj mm) in relation to the axial movement of the duplex worm shaft (V mm) can be calculated from the formula below.

$$\Delta j = 2V \frac{m_b - m_a}{m_a + m_b}$$

Where

m_a = Nominal Axial Module - (0.01 × Nominal Axial Module)

m_b = Nominal Axial Module + (0.01 × Nominal Axial Module)

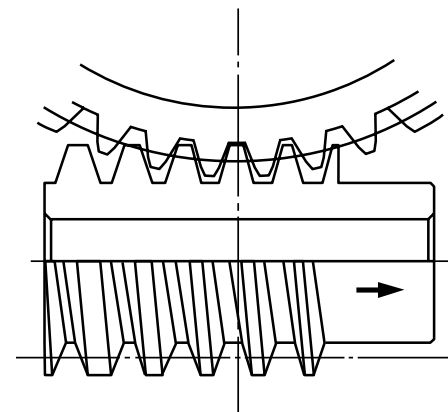

Reference tooth

Moving the worm in the direction of the arrow causes the backlash to decrease.

Fig. 2

(CAUTION) The KHK duplex worm is designed so that, for all modules, the backlash reduces by 0.02 mm when the worm is shifted 1 mm.

Application Examples

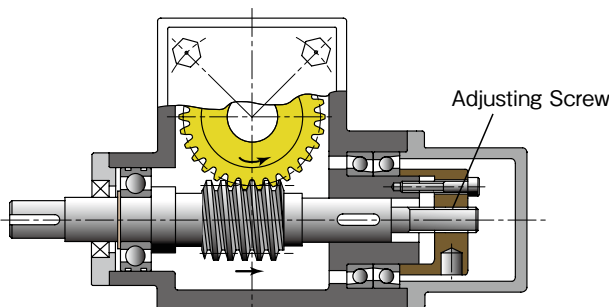

Adjustment by using Screws *

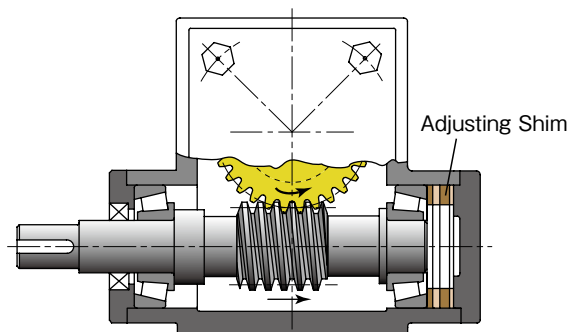

Adjustment by using Shims *

* The illustration above is a design example, not a design for machinery or a device in actual use.

Point of caution during assembly

KHK duplex worm gears differs in module between the right and left tooth surface and, therefore, you must orient the worm and worm wheel properly. Please carefully verify the following two aspects before proceeding with assembly.

1. Verifying the orientation of assembly

An arrow indicating the orientation of assembly is stamped on both the duplex worm and worm wheel. When assembling the worm and worm wheel, check the worm wheel of the arrow mark on the front such that the direction of arrow mark on the worm coincides with that on the worm wheel. Should the assembly be incorrect, the center distance "a" will become larger than the normal distance, resulting in difficulty of assembly and improper gear engagement. (Fig.3)

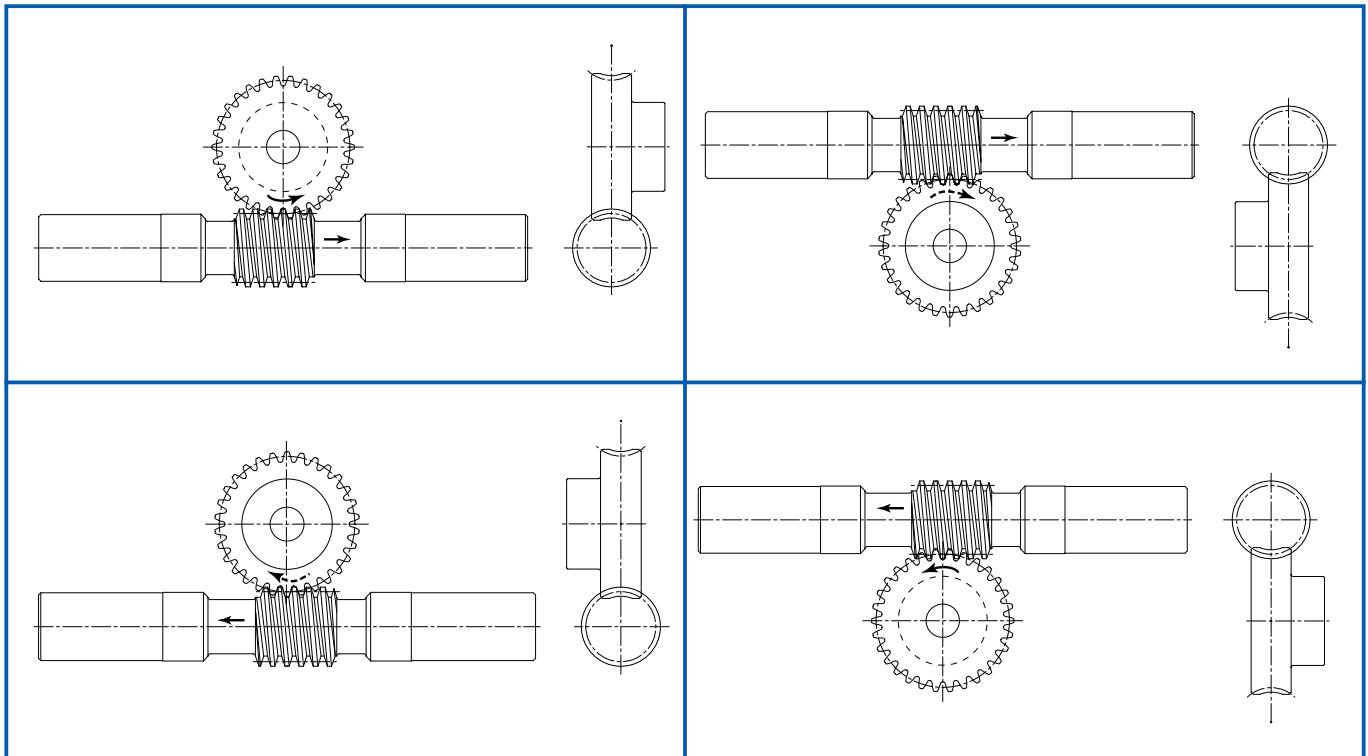

Arrow mark indicates the correct orientation of two gears when assembled. As shown, the two arrows must point in the same direction.

Fig. 3

2. Verifying the reference position

A V-groove (60°, 0.3 mm deep line) on tip peripheral of the duplex worm tooth marks the reference tooth. The gear set is designated to have a backlash of nearly zero (± 0.045) when the reference tooth is positioned in alignment with the center of rotation of the worm wheel with the center distance set at the value "a". (Fig.4)

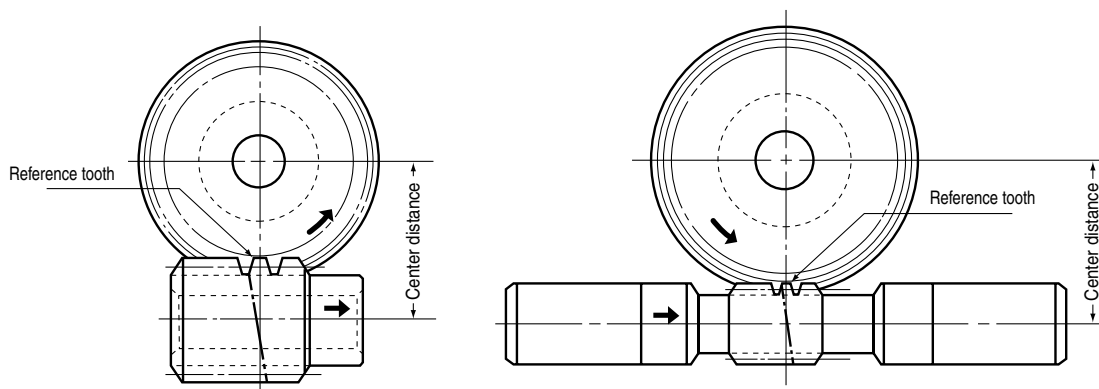

Fig. 4

Spur Gears

Helical Gears

Internal Gears

Racks

CP Racks & Pinions

Miter Gears

Bevel Gears

Screw Gears

Worm Gear Pair

Bevel Gearboxes

Other Products